

Railroader

A 922 Rail

Litronic®

Operating Weight:
19,900 – 22,800 kg

Engine:
110 kW / 150 HP



LIEBHERR

A 922 Rail Litronic

Operating Weight:

19,900 – 22,800 kg

Engine:

110 kW/ 150 HP

Performance

Compact, flexible –
Perfect combination for
maximum performance



Economy

A sound investment –
Optimum economy and
environmentally friendly

Reliability

Competence, consistency,
innovation – Proven experience

Comfort

Ergonomic excellence –
Superior cabin design for
operator comfort and wellbeing

Maintainability

Service every step of the way –
Simple, fast and reliable



Performance



Compact, flexible – Perfect combination for maximum performance

Liebherr railroaders are used on building sites where they embody force and speed. Using them, machine operators achieve impressive levels of performance, day-in and day-out. It is based on the powerful Liebherr engine with its high torque, which drives two independent pumps as standard. This ensures the availability of a high flow rate in all situations. More can be achieved faster with Liebherr railroader A 922 Rail.

Maximum Performance

Lifting more

The intelligent structure of the uppercarriage and the separate mounting of the hoist cylinders permit a superior lift capacity on rail and on the road. The A 922 Rail Litronic is a base carrier that can be used with a wide range of hydraulic attachments.

Being faster

The A 922 Rail Litronic enables a high working speed, even when movements of attachment are performed in parallel. Excavating, backfilling and profiling tasks can be completed faster, new tasks can be started sooner. The speed of the machine can be adjusted easily using the MODE switch for load lifting work or grading work. A further, independent variable displacement pump is provided for the rail bogies. This guarantees optimal load distribution onto the rails.

Precise Work

Working with Precision

The exceptional sensitivity of the hydraulic system allows precise working at high speeds, and with movements in parallel. This means the machine operator can carry out the most challenging tasks in a short time, not only at reduced engine but also with maximum performance output from the machine. Maximum power and maximum forces are always available. It is no problem to simultaneously move along the tracks and operate the equipment. A wide range of tasks – for example levelling the ballast or work on embankments – can be performed perfectly.

Innovative Hydraulics

Liebherr variable displacement double pump with independent control circuits provides excellent power and speed. Hydraulic attachments – such a rammer, tamping machine and mulcher can be operated independently from work and travel movements of the Liebherr railroaders.

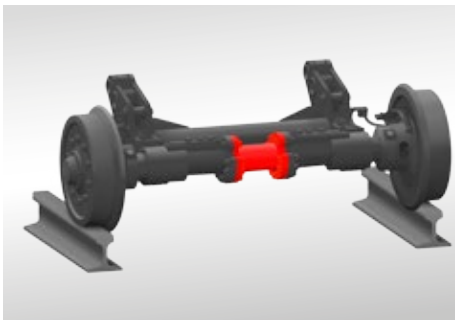

Gauge

Axle Variation

- Realization of different special gauges
- Simple adjustment of the gauge
- Worldwide applications

Maximum Payloads

- Power Lift – increase in hydraulically-limited payloads
- Heavy counterweight for even higher load bearing capacity
- Greater stability thanks to 4-point outriggers

Travel Drive

- Newly developed travel drive with high traction force for high travel speeds both in the plane and on gradients
- Reduces travel time between tasks and on the building site
- Faster on site – more productive

Economy



A sound investment – Optimum economy and environmentally friendly

Liebherr railroaders are machines that combine high productivity and flexibility with excellent levels of economy – and all this comes as standard from the factory. The A 922 Rail Litronic is specifically designed this way, perfectly coordinated to the attachments it is extremely versatile. The machine is capable of working independently and flexibly even on inaccessible sections of track. On request, the efficiency of each wheeled excavator can be boosted further with a Liebherr quick coupling system. For more return from each operating hour.

Maximum Efficiency

Liebherr Working Tools and LIKUFIX

To boost the productivity of its construction machines, Liebherr offers a broad range of working tools for different fields of application. Furthermore, the hydraulic excavators can also be equipped with the Liebherr LIKUFIX hydraulic quick coupling system. The combination of a hydraulic Liebherr quick coupling system with the LIKUFIX coupling block permits fast safe changing of mechanical and hydraulic working tools from the operator's cabin. This boosts productivity on average by 30%. The construction process is accelerated, and orders are completed faster. That enables more turnover to be achieved per machine.

Engine Idling

The standard automatic idling function reduces the engine speed to idle as soon as the operator takes his hand from the joystick so that no hydraulic function is activated. Proximity sensors in the joystick levers restore the original engine speed as soon as the operator's hand is moved towards the lever again. This ensures that the set engine speed is available immediately. The result is a combination of fuel saving and reduced noise level.

Increased Productivity

Low Emissions and Low Operating Costs

The Liebherr D 834 diesel engine sets the benchmark for consumption in its performance class while adhering to emissions stage IIIB with a maintenance-free oxidation catalyst. A Liebherr particulate filter is available as an option (use depends on legislative regulations). The environment is protected by adhering to the emissions specifications. Fewer emissions. Lower operating costs. More economic environmental protection.

Efficient Management

LiDAT, Liebherr's own data transmission and positioning system, facilitates efficient management, monitoring and control of the entire fleet in terms of machinery data recording, data analysis, fleet management and service. All of the important machinery data can be viewed at any time in a web browser. LiDAT provides you comprehensive work deployment documentation, greater availability thanks to shorter downtimes, faster support from the manufacturer, quicker detection of strain/overload and subsequently a longer service life of the machine as well as greater planning efficiency. This service includes 1 year of use free of charge as standard for the wheeled excavator A 922 Rail.

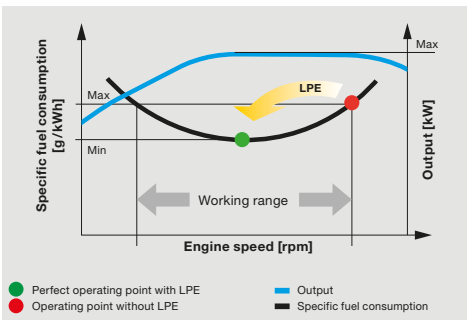

Add-On-Axle

- In Germany, nationwide road travel approval
- Load distribution on three axles
- Securing of new areas of use
- Higher load capacities (up to 15%) thanks to the use of the heavy counterweight

Low Fuel Consumption Thanks to Intelligent Machine Control

- Liebherr-Power Efficiency (LPE) optimises the interaction of the drive components in terms of efficiency
- LPE enables machine operation in the area of the lowest specific fuel use for less consumption and greater efficiency with the same performance

Liebherr Quick Coupling System LIKUFIX

- Faster and safer changing of mechanical and hydraulic working tools from the operator's cabin
- Machine utilization increased to up to 90% thanks to extended deployment options
- Visual and acoustic check of correct locking position of tool at quick coupling system by two proximity sensors

Reliability



Competence, consistency, innovation – Proven experience

Reliability offers safety. Safety that significantly influenced the success of a project. Liebherr stands for safety – with reliable railroad machines used on rail, in rough terrain or on the road. Comprehensive security functionality that pay off.

More Safety

Quality

Key components such as the diesel engine, hydraulic components, electronic components, slewing ring and swing drive are developed, tested and produced by Liebherr itself. The significant expertise of production ensures the highest quality and gives optimum coordination of components. The high-quality Liebherr components are also used in many other sectors and products.

Expertise

Liebherr has been developing and producing hydraulic excavators since 1954, and has since 1967 experience in the manufacture of railroaders. This experience and the feedback from customers, sales and service form the basis for putting innovative ideas into practice. The result: wheeled excavators with excellent quality and reliability.

High Machine Availability

Safety

Besides the performance and efficiency of a railroader, the safety of the operator and the machine must always be paramount. Numerous equipment features such as the standard pipe fracture safety valves on the lifting and stick cylinders, electronic lift limitation, electronic swivel limitation, load moment limitation according to EN 15746-2, laminated safety glass smash-resistant, rollover protection structure (ROPS) and an emergency exit through the rear window provide maximum safety in all operations.

Excellent All-round Vision

The large areas of glass and the rear and side area monitoring systems provide the operator with an excellent view of his working area and the zone around the machine. This perfect view enhances the operator's safety and ensures that in turn he can handle the machine safely at all times.

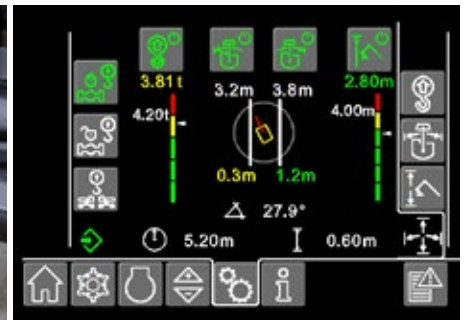

QPDM – Quality and Process Data Management

- QPDM allows production data to be logged, documented and evaluated
- Automation of documentation and test specifications
- Ability to handle large quantities and maintain uniform high quality

Rail Wheel Brakes

- Brakes integrated in the rail wheel as standard shorten the braking distance in all situations to increase safety on the track even more
- Braking effect even in raised position
- Fast and simple change of the track wheel

Virtual Wall – Extended Workspace Boundary

- Reliable workspace boundary irrespective of outreach
- Liebherr software adapted to the machine

Comfort



Ergonomic excellence – Superior cabin design for operator comfort and wellbeing

The modern Liebherr operator's cab is the largest in this machine class, and offers the best conditions for healthy, focussed and productive working. Standard features include an air-sprung operator seat with seat heating, automatic air conditioning and the ergonomically arranged control elements with touchscreen indicating unit. An example of the extensive safety equipment is the rollover protection structure (ROPS) for the cab fitted as standard according to ISO 12117-2 as well as the standard windows made from impact-resistant laminated safety glass.

First-class Cab

Automatic Air Conditioning

The automatic air conditioning offers convincingly intuitive operation. Temperature, blower setting and the various air nozzles in the head, chest and foot areas are set using the touch screen on the indicating unit. The defrost/defog one button function clears fogged up windows in the shortest possible time. The filter for the cab air can be changed easily and conveniently from the outside.

Operator Seats

The Standard, Comfort and Premium operator seat versions available have recognized orthopedic properties, and offer sitting comfort at the highest level. Even the standard operator seat offers an extensive range of features such as air suspension, seat heating, headrest, lumbar support and many more.

Low Noise Levels

The use of viscoelastic mounts, good insulation and low-noise diesel engines from Liebherr minimises noise emissions and vibrations. The noise levels are just 72 dB(A) in the operator's cab and 100 dB(A) outside.

Comfortable Operation

Radio with Hands-free Device

The radio can be equipped with an MP3-compatible USB slot and integrated hands-free device, which means that calls can even be taken while working with the machine. Operation of the radio is by means of the touchscreen colour display. Station search, volume control and mute can be controlled with ease. Simple operation for greater comfort.

Excellent All-round Vision

The large areas of glass and the rear and side area monitoring systems provide the operator with an excellent view of his working area and the zone around the machine. This perfect view enhances the operator's safety and ensures that in turn he can handle the machine safely at all times.

Detailed Solutions

The A 922 Rail Litronic offers numerous detailed solutions for greater comfort and efficiency. The railroader rides evenly on the tracks thanks to the constant automatic level control of the rail bogies. The tyre traction can be adjusted easily via display. This ensures optimal tyre traction at all times. In addition, the proven traction increase ensures greater pulling power with particularly difficult rail conditions.



Liebherr Proportional Control

- All work and travel movements are adjustable separately from each other
- Up to five operators can save their individual settings
- More efficient operation for greater productivity

Maximum Safety

- More convenient and safer entry and exit in and out of the cab thanks to added width from the folding arm console
- Three entry steps with standard anti-slip galvanised plates provide a boost to safety

Intuitive Operation

- Display of the machine data and camera image on two 7-inch displays with touch screen and direct access via menu bar
- 10 user-programmable memory slots for working tools, which can be used for quickly and easily setting the oil pressure and oil flow at the push of a button when changing tools
- Quick access keys can be programmed by the machine operator for frequently used menu items

Maintainability



Service every step of the way – Simple, fast and reliable

Liebherr railroaders are not only powerful, robust, precise and efficient, they also impress with the service-orientated machine design. Maintenance is performed quickly, simply and safely. This reduces maintenance costs and keeps machine downtimes to a minimum.

Simplified Maintenance Concept Your Competent Service Partner

Service-based Machine Design

The service-based machine design guarantees short servicing times, and minimising maintenance costs due to the time it saves. All the maintenance points are easily accessible from the ground and easy to reach due to the large, wide-opening service doors. The enhance service concept places the maintenance points close to each other and reduces their number to a minimum. This means that service work can be completed even more quickly and efficiently.

Hydraulic Oils with Added Value

Liebherr hydraulic oils achieve a service life of 6,000 operating hours plus. Instead of having defined change intervals, the results of the oil analysis (every 1,000 operating hours or after one year) determine when the oil needs to be changed. The unique Liebherr Hydraulic Plus oil can even achieve a service life of 8,000 operating hours and more at the same time as reducing fuel consumption by up to 5%.

Remanufacturing

The Liebherr remanufacturing program offers cost-effective reconditioning of components to the highest quality standards. Various reconditioning levels are available including replacement components and general overhaul or repair. The customer receives components with original part quality at a reduced cost.

Competent Advice and Service

Competent advice is a given at Liebherr. Experienced specialists provide advice for your specific requirements: application-oriented sales support, service agreements, cost effective repair alternatives, original parts management, as well as remote data transmission for machine planning and fleet management.



Lubricating During Work

- Fully automatic central lubrication system for the attachment and slewing ring
- Can be optionally expanded to the connecting link and quick coupler
- The grease tank of the central lubrication system is located behind the left service door
- Lubricating without interrupting work for higher productivity

Maintenance without Draining Oil

- Standard shut-off valve for disconnecting the oil tank from the hydraulic system
- For simple maintenance work on the hydraulic components without draining the hydraulic oil
- Reduced maintenance time for higher machine availability

Rapid Spare Parts Service

- 24-hour delivery: Spare parts service is available for our dealers around the clock
- Electronic spare parts catalogue: Fast and reliable selection and ordering via the Liebherr online portal
- With online tracking, the current processing status of your order can be viewed at any time

Railroader A 922 Rail Litronic Overview

Superbly Designed

Attachment for Maximum Reliability

- Load torque limitation (RCI/RCL)
- Second high pressure circuit
- Electronic lift limitation and swivel limitation
- Liebherr hydraulic cylinders
- Pipe fracture safety valves hoisting and stick cylinders
- Optimised bucket stick for application under electrical overhead lines
- Liebherr quick coupling systems (optional)
- Wide selection of Liebherr working tools (optional)

Elaborate Maintenance Concept for Maximum Productivity

- Fully automatic central lubrication system for uppercarriage and attachment
- Large, wide-opening service doors
- Central maintenance points accessible from the ground
- Shut-off device for hydraulic oil
- Liebherr hydraulic oil, biologically degradable (optional)
- Cab air filter can be replaced quickly and conveniently from outside
- Two lockable storage boxes
- Divided rail wheel





Ergonomic Operator's Work Station for Maximum Comfort

- Double cab with passenger seat
- Operator's seat Comfort or Premium (optional)
- Automatic air-conditioning system
- Two 7" high resolution colour display with touchscreen operation
- Operator profile, personalised
- Tool Control for working tools
- Resonant arm console and ergonomic joysticks
- Proportional control with 4-way mini-joystick
- Large windows
- Windshield wiper with interval switching and washer, roof window and rear window
- Convenient radio operation with hands-free device
- LED headlights (optional)
- Rear monitoring
- Side monitoring

Clever Technology for Maximum Performance and Economy

- Liebherr diesel engine according to stage IIIB with oxidation catalyst
- Pre-installation particle filter with silencer module
- Dual-circuit load-sensing-control
- Liebherr Power Efficiency (LPE)
- MODE selection (Sensitive, ECO, Power, Power-Plus)
- Sensor-controlled automatic idling system

Technical Data



Diesel Engine

Rating per ISO 9249	110 kW (150 HP) at 1,800 RPM
Model	Liebherr D834
Type	4 cylinder in-line
Bore/Stroke	108/125 mm
Displacement	4.6 l
Engine operation	4-stroke diesel Common-Rail turbo-charged and after-cooler reduced emissions
Air cleaner	dry-type air cleaner with pre-cleaner, primary and safety elements
Engine idling	sensor controlled
Electrical system	
Voltage	24 V
Batteries	2 x 135 Ah / 12 V
Alternator	three-phase current 28 V / 110 A
Stage IIIB	
Harmful emissions values	in accordance with 97/68/EG stage IIIB
Emission control	pre-installation particle filter with silencer module
Option	Liebherr particle filter
Fuel tank	330 l



Cooling System

Diesel engine	water-cooled compact cooling system comprising cooling unit for water, hydraulic oil and charge air with stepless thermostatically controlled fan
----------------------	--



Hydraulic Controls

Power distribution	via control valves with integrated safety valves, simultaneous and independent actuation of chassis, swing drive and attachment
Servo circuit	
Attachment and swing	electroproportional via joystick levers
Chassis	electroproportional via foot pedal
Additional functions	via switch or electroproportional foot pedals
Proportional control	proportionally acting transmitters on the joysticks for additional hydraulic functions



Hydraulic System

Hydraulic pump	for attachment and travel drive	Liebherr axial piston variable displacement double pump
Max. flow		2 x 215 l/min.
Max. pressure		350 bar / PowerLift 375 bar
Hydraulic pump regulation and control		Liebherr-Synchron-Comfort-system (LSC) with electronic engine speed sensing regulation, pressure and flow compensation, torque controlled swing drive priority
Hydraulic tank		130 l
Hydraulic system		max. 300 l
Hydraulic oil filter		1 main return filter with integrated partial micro filtration (5 µm)
MODE selection		adjustment of engine and hydraulic performance via a mode pre-selector to match application, e.g. for especially economical and environmentally friendly operation or for maximum digging performance and heavy-duty jobs
S (Sensitive)		mode for precision work and lifting through very sensitive movements
E (Eco)		mode for especially economical and environmentally friendly operation
P (Power)		mode for high performance with low fuel consumption
P+ (Power-Plus)		mode for highest performance and for very heavy duty applications
Engine speed and performance setting		stepless alignment of engine output and hydraulic power via engine speed Tool Control: ten preadjustable pump flows and pressures for add on tools



Swing Drive

Drive	Liebherr axial piston motor with torque control and integrated brake valve, Liebherr planetary reduction gear
Swing ring	Liebherr, sealed race ball bearing swing ring, internal teeth
Swing speed	0 – 9.0 RPM stepless
Swing torque	50 kNm
Holding brake	wet multi-disc (spring applied, pressure released) pedal controlled positioning swing brake



Operator's Cab

Double cabin	ROPS safety cab structure (roll-over protection system) with individual windscreens or featuring a slide-in subpart under the ceiling, work headlights integrated in the ceiling, operator's door with a sliding window (can be opened on both sides), large stowing and depositing possibilities, shock-absorbing suspension, sounddamping insulating, tinted laminated safety glass, separate window shades for the sunroof window and windscreen
Operator's seat Standard	air cushioned operator's seat with headrest, lap belt, seat heater, manual weight adjustment, adjustable seat cushion inclination and length and mechanical lumbar vertebrae support
Operator's seat Comfort (Option)	in addition to operator's seat standard: lockable horizontal suspension, automatic weight adjustment, adjustable suspension stiffness, pneumatic lumbar vertebrae support and passive seat climatization with active coal
Operator's seat Premium (Option)	in addition to operator's seat comfort: active electronic weight adjustment (automatic readjustment), pneumatic low frequency suspension and active seat climatization with active coal and ventilator
Control system	joysticks with arm consoles and swivel seat
Operation and displays	large high-resolution operating unit, self-explanatory, colour display with touchscreen, video-compatible, numerous setting, control and monitoring options, e.g. air conditioning control, fuel consumption, machine and tool parameters, separate display for rear view and side view monitoring
Air-conditioning	automatic air-conditioning, recirculated air function, fast de-icing and demisting at the press of a button, air vents can be operated via a menu; recirculated air and fresh air filters can be easily replaced and are accessible from the outside; heating-cooling unit, designed for extreme outside temperatures, sensors for solar radiation, inside and outside temperatures



Undercarriage

Drive	two speed power shift transmission with additional creeper speed, Liebherr axial piston motor with functional brake valve on both sides
Pulling force	117 kN
Travel speed	0 – 3.5 km/h stepless (creeper speed off-road) 0 – 7.0 km/h stepless (off-road) 0 – 13.0 km/h stepless (creeper speed on-road) 0 – 20.0 km/h stepless (road travel) 0 – max. 25.0 or 30.0 km/h Speeder (Option)
Driving operation	automotive driving using accelerator pedal, cruise control function: storage of variable accelerator pedal positions, both off-road, on-road and on-rail
Axes	automatic or operator controlled front axle oscillation lock
Option	axle with wheel head width 2,100 mm and differential lock 100 % in track operation
Service brake	two circuit travel brake system with accumulator; road axle wet and backlash-free disc brake; rail wheels with drum brake
Holding brake	wet multi-disc (spring applied, pressure released)
Wagon braking system	1 circuit compressed air brake for railway wagon
Option	2 circuit compressed air brake for trailer 2 circuit hydraulic brake for trailer
Rail guide	standard gauge 1,435 mm
Option	width gauge, narrow gauge type friction drive
Stabilization	without outriggers
Option	4 point outriggers



Attachment

Type	high-strength steel plates at highly stressed points for the toughest requirements. Complex and stable mountings of attachment and cylinders
Hydraulic cylinders	Liebherr cylinders with special seal system as well as shock absorption
Bearings	sealed, low maintenance



Complete Machine

Lubrication	Liebherr central lubrication system for uppercarriage and attachment, automatically
Noise emission	
ISO 6396	L_{pA} (inside cab) = 72 dB(A)
2000/14/EC	L_{WA} (surround noise) = 100 dB(A)

Dimensions

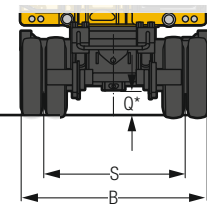
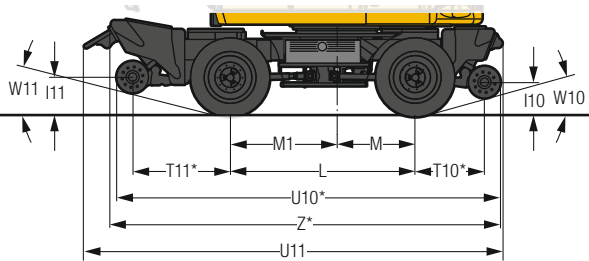
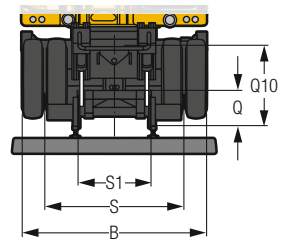
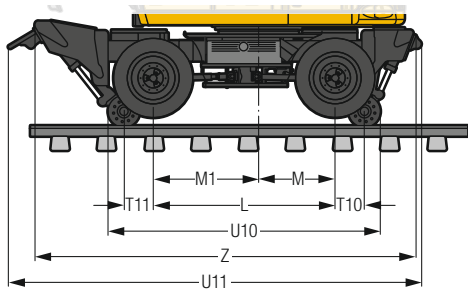
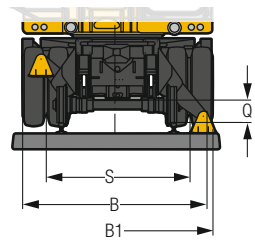
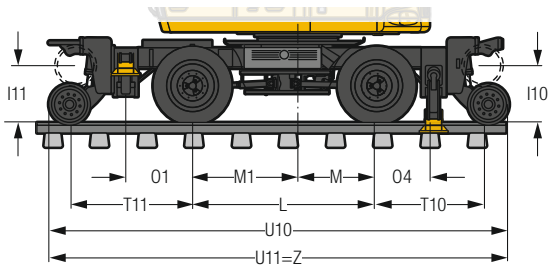
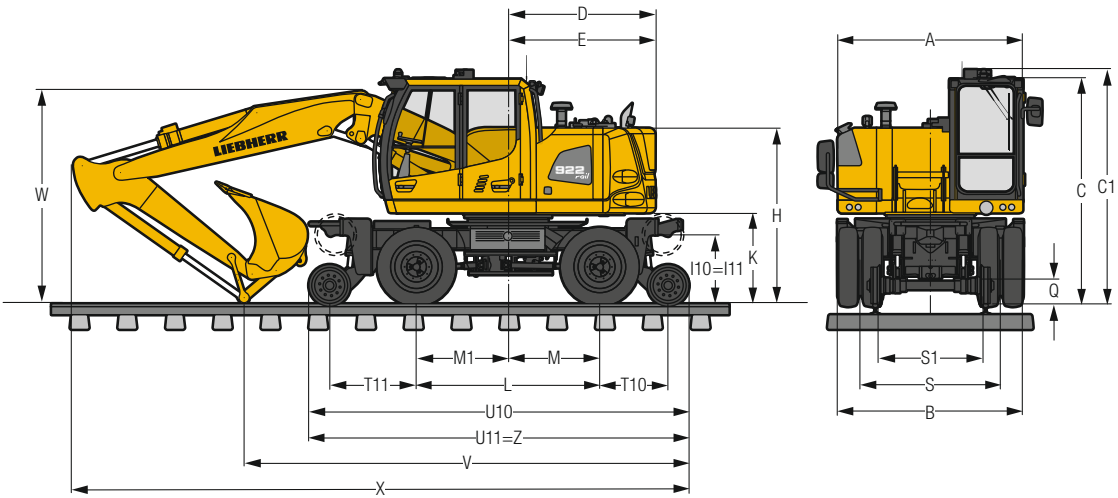

	without outriggers / Symetric Rail	4 point outriggers	Friction drive narrow gauge rail	Friction drive narrow gauge road
	mm	mm	mm	mm
A	2,520	2,520	2,520	2,520
B	2,550	2,550	2,550	2,550
B1	–	2,700	–	–
C*	3,063	3,063	3,213	3,063
C1	3,287	3,287	–	–
D	2,000	2,000	2,000	2,000
E	2,000/2,050	2,000/2,050	2,000/2,050	2,000/2,050
H	2,395	2,395	2,546	2,395
I10	780	780	–	509
I11	780	780	–	509
K	1,238	1,238	1,389	1,238
L	2,500	2,500	2,500	2,500
M	1,250**/1,050	1,050	1,250**/1,050	1,050
M1	1,250	1,450	1,450	1,450
O1	–	920	–	–
O4	–	770	–	–
Q	340	340	494	340
Q10	–	–	1,117	–
S	1,912	1,912	1,912	1,912
S1	1,435	–	1,000	1,000
T10	930	1,520	400	935
T11	1,180	1,670	400	1,318
U10	5,178	6,258	3,744	5,196
U11	5,178	6,258	5,668	5,668
W10	–	–	–	14°
W11	–	–	–	16°
Z	5,178	6,258	5,220	5,220

* ohne DB-Leuchte und Scheibenwischer, kann für Transport abgenommen werden

** Symetric Rail

E = Tail radius

Bereifung 10.00-20

	Stick m	Two-piece boom 5.10 m		
		without outriggers mm	4 point outriggers mm	Symetric Rail mm
V	1.85	6,300	7,450*	6,500
	2.05	6,050	7,200*	6,250
	2.25	6,500*	7,200*	6,050
W	2.65	6,350*	6,900* ¹⁾	6,100*
	1.85	3,000	3,000*	3,000
	2.05	3,000	3,000*	3,000
X	2.25	3,050*	3,100*	3,000
	2.65	3,150*	3,000* ¹⁾	3,150*
	1.85	8,450	9,550*	8,650
X	2.05	8,300	9,450*	8,500
	2.25	8,950*	9,400*	8,500
	2.65	8,900*	9,450* ¹⁾	8,700*

	Stick m	Offset two-piece boom 5.25 m		
		without outriggers mm	4 point outriggers mm	Symetric Rail mm
V	1.85	7,000	7,600	7,200
	2.05	6,550	7,700*	6,750
	2.25	6,200	7,350*	6,400
W	2.65	6,400*	7,000* ¹⁾	6,200*
	1.85	3,100	3,100	3,100
	2.05	3,100	3,100*	3,100
X	2.25	3,150	3,100*	3,100
	2.65	3,150*	3,050* ¹⁾	3,150*
	1.85	8,650	9,200	8,850
X	2.05	8,500	9,650*	8,700
	2.25	8,450	9,600*	8,650
	2.65	9,100*	9,600* ¹⁾	8,900*

Dimensions are with attachment over steering axle

* Attachment over digging axle for shorter transport dimensions

¹⁾ without backhoe bucket

Ditch Cleaning Bucket

with Two-Piece Boom 5.10 m

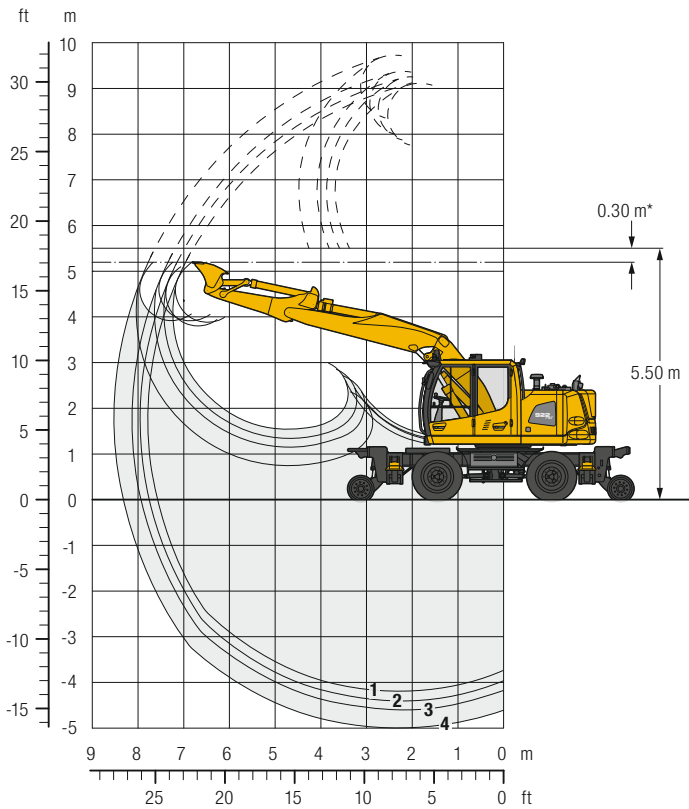

* Safety distance to overhead wires

Digging Envelope

		1	2	3	4
Stick length	m	1.85	2.05	2.25	2.65
Max. digging depth	m	4.20	4.40	4.60	5.00
Max. reach at ground level	m	7.55	7.75	7.95	8.35
Max. dumping height	m	7.75	7.90	8.00	8.35
Max. dumping height under overhead wires	m	4.00	4.00	4.05	4.05
Max. teeth height	m	9.05	9.20	9.35	9.70

Digging Forces

		1	2	3	4
Max. digging force	kN	100.2	93.0	86.8	76.7
	t	10.2	9.5	8.8	7.8
Max. breakout force	kN	105.4	105.4	105.4	105.4
	t	10.7	10.7	10.7	10.7

Max. breakout force with ripper bucket

134.7 kN (13.7 t)

Operating Weight

The operating weight includes the basic machine with 8 tyres plus intermediate rings, two-piece boom 5.10 m, stick 2.25 m and ditch cleaning bucket 2,000 mm / 0.65 m³.

Undercarriage versions	Weight (kg)
A 922 Rail Litronic Symetric Rail	19,900
A 922 Rail Litronic without outriggers	19,900
A 922 Rail Litronic with 4 point outriggers	21,600

Ditch Cleaning Buckets Machine stability per ISO 10567* (75% of tipping capacity)

Cutting width mm	Capacity ISO 7451 ¹⁾ m ³	Weight kg	without outriggers								4 pt. outriggers								Symetric Rail							
			on rail				on tyres				on rail				on tyres				on rail				on tyres			
			Stick length (m)		Stick length (m)		Stick length (m)		Stick length (m)		Stick length (m)		Stick length (m)		Stick length (m)		Stick length (m)		Stick length (m)		Stick length (m)		Stick length (m)			
1,600	0.80	445	■	■	△	△	■	■	■	■	■	■	■	△	■	■	■	■	■	■	△	△	■	■	■	■
2,000	0.65	388	■	■	■	■	■	■	■	■	■	■	■	■	■	■	■	■	■	■	■	■	■	■	■	■
1,600 ²⁾	0.80	766	△	△	-	-	■	■	■	■	△	△	△	-	■	■	■	■	△	△	-	-	■	■	■	■
2,000 ²⁾	0.70	811	△	△	△	-	■	■	■	■	■	■	■	■	■	■	■	■	△	△	△	-	■	■	■	■

* Indicated loads are based on ISO 10567 and do not exceed 75% of tipping or 87% of hydraulic capacity, max. stick length without quick coupler, lifted 360° on firm with blocked oscillating axle

¹⁾ comparable with SAE (heaped)

²⁾ with 2 x 50° rotator

Max. material weight ■ = ≤ 1.8 t/m³, ■ = ≤ 1.5 t/m³, △ = ≤ 1.2 t/m³, - = not authorised

Lift Capacities

with Two-Piece Boom 5.10 m (without Outriggers) with Tail Radius 2,000 mm

Stick 1.85 m

m	Undercarriage	3.0 m		4.5 m		6.0 m		7.5 m		m
		on rail	on tyres	on rail	on tyres	on rail	on tyres	on rail	on tyres	
9.0	on rail									
	on tyres									
7.5	on rail	6.8	7.9*					4.2	5.2*	4.0
	on tyres	7.9*	7.9*					5.2*	5.2*	
6.0	on rail	6.7*	6.7*	3.7	6.9*			2.5	3.9*	5.6
	on tyres	6.7*	6.7*	5.0	6.9*			3.3	3.9*	
4.5	on rail	6.6	10.3*	3.8	7.4*	2.3	6.2*	1.9	3.5*	6.5
	on tyres	8.9	10.3*	5.0	7.4	3.1	4.7	2.6	3.5*	
3.0	on rail	6.3	10.2*	3.7	8.4*	2.3	6.4*	1.7	3.4*	7.0
	on tyres	8.6	10.2*	4.9	7.3	3.0	4.7	2.3	3.4*	
1.5	on rail	6.3	12.3*	3.6	8.9*	2.2	6.6*	1.6	3.4*	7.1
	on tyres	8.6	12.3*	4.8	7.3	3.0	4.6	2.2	3.4*	
0	on rail	5.8	14.0*	3.4	9.0*	2.1	6.6*	1.6	3.7*	6.9
	on tyres	8.2	13.9	4.6	7.3	2.9	4.5	2.3	3.6	
-1.5	on rail	5.6	14.4*	3.1	9.2*	2.0	5.2*	1.9	4.2*	6.3
	on tyres	7.9	14.3	4.3	7.0	2.8	4.4	2.6	4.1	
-3.0	on rail	5.5	11.9*	3.0	5.7*			3.0	5.6*	4.5
	on tyres	7.8	11.9*	4.2	5.7*			4.2	5.6*	
-4.5	on rail									
	on tyres									

Stick 2.05 m

m	Undercarriage	3.0 m		4.5 m		6.0 m		7.5 m		m
		on rail	on tyres	on rail	on tyres	on rail	on tyres	on rail	on tyres	
9.0	on rail									
	on tyres									
7.5	on rail									3.8
	on tyres									4.2*
6.0	on rail									2.3
	on tyres									3.4*
4.5	on rail									1.8
	on tyres									3.1*
3.0	on rail									1.6
	on tyres									3.0*
1.5	on rail									1.5
	on tyres									3.1*
0	on rail									1.6
	on tyres									3.3*
-1.5	on rail									1.8
	on tyres									3.9*
-3.0	on rail									2.6
	on tyres									5.0*
-4.5	on rail									
	on tyres									

Stick 2.25 m

m	Undercarriage	3.0 m		4.5 m		6.0 m		7.5 m		m
		on rail	on tyres	on rail	on tyres	on rail	on tyres	on rail	on tyres	
9.0	on rail									
	on tyres									
7.5	on rail									3.5
	on tyres									3.6*
6.0	on rail									2.2
	on tyres									2.9*
4.5	on rail									1.7
	on tyres									2.7*
3.0	on rail									1.5
	on tyres									2.7*
1.5	on rail									1.4
	on tyres									2.8*
0	on rail									1.5
	on tyres									3.0*
-1.5	on rail									1.7
	on tyres									3.5*
-3.0	on rail									2.3
	on tyres									4.5*
-4.5	on rail									
	on tyres									

Stick 2.65 m

m	Undercarriage	3.0 m		4.5 m		6.0 m		7.5 m		m
		on rail	on tyres	on rail	on tyres	on rail	on tyres	on rail	on tyres	
9.0	on rail									4.7*
	on tyres									4.7*
7.5	on rail									2.8*
	on tyres									2.8*
6.0	on rail									1.9
	on tyres									2.4*
4.5	on rail									1.6
	on tyres									2.2*
3.0	on rail									1.4
	on tyres									2.2*
1.5	on rail									1.3
	on tyres									2.3*
0	on rail									1.3
	on tyres									2.4*
-1.5	on rail									1.5
	on tyres									2.8*
-3.0	on rail									1.9
	on tyres									3.9*
-4.5	on rail									
	on tyres									

Height Can be slewed through 360° In longitudinal position of undercarriage Max. reach * Limited by hydr. capacity

The lift capacities are stated in metric tonnes (t) with PowerLift of 375 bar at the stick end without tools. This applies to a firm flat substrate with a closed steering axle. These capacities can be slewed through 360° with the undercarriage in the transverse position. Capacities in the longitudinal position of the undercarriage (+/- 15°) are specified over the steering axle with the stabilizers raised. The values apply when the adjusting cylinder is in the optimal position. Indicated loads based on the ISO 10567 standard and do not exceed 75 % of tipping or 87 % of hydraulic capacity, or are limited by the permissible load of the load lift hook.

In accordance with the harmonised European Standard EN 474-5, hydraulic excavators used for lifting operations must be equipped with pipe fracture safety valves, an overload warning device, a load lift hook and a lift capacity chart.

Please note that the stability will be reduced by approx. 20 % in case of a 100 mm cant and 40 % in case of a 200 mm cant.

Lift Capacities

with Two-Piece Boom 5.10 m (4 Point Outriggers) with Tail Radius 2,000 mm

Stick 1.85 m

m	Undercarriage	3.0 m		4.5 m		6.0 m		7.5 m		m
9.0	outriggers raised, on rail									
	outriggers raised, on tyres									
	4 point outriggers down									
7.5	outriggers raised, on rail	7.2	7.9*					4.5	5.2*	4.0
	outriggers raised, on tyres	7.9*	7.9*					5.2*	5.2*	
	4 point outriggers down									
6.0	outriggers raised, on rail	6.7*	6.7*	4.0	6.9*			2.7	3.9*	5.6
	outriggers raised, on tyres	6.7*	6.7*	5.3	6.9*			3.6	3.9*	
	4 point outriggers down	6.7*	6.7*	6.6	6.9*			3.9*	3.9*	
4.5	outriggers raised, on rail	7.0	10.3*	4.0	7.4*	2.4	6.2*	2.1	3.5*	6.5
	outriggers raised, on tyres	9.4	10.3*	5.3	7.4*	3.3	5.0	2.8	3.5*	
	4 point outriggers down	10.3*	10.3*	6.5	7.4*	4.2	6.2*	3.5*	3.5*	
3.0	outriggers raised, on rail	6.7	10.2*	4.0	8.4*	2.4	6.4*	1.8	3.4*	7.0
	outriggers raised, on tyres	9.1	10.2*	5.2	7.7	3.3	5.0	2.5	3.4*	
	4 point outriggers down	10.2*	10.2*	6.4	8.4*	4.2	6.4*	3.2	3.4*	
1.5	outriggers raised, on rail	6.7	12.3*	3.8	8.9*	2.3	6.6*	1.7	3.4*	7.1
	outriggers raised, on tyres	9.1	12.3*	5.1	7.6	3.2	4.9	2.4	3.4*	
	4 point outriggers down	11.6	12.3*	6.4	8.9*	4.1	6.6*	3.1	3.4*	
0	outriggers raised, on rail	6.2	14.0*	3.6	9.0*	2.2	6.6*	1.8	3.7*	6.9
	outriggers raised, on tyres	8.8	14.0*	4.9	7.8	3.1	4.8	2.5	3.7*	
	4 point outriggers down	11.7	14.0*	6.3	9.0*	4.0	6.6*	3.2	3.7*	
-1.5	outriggers raised, on rail	6.0	14.4*	3.4	9.2*	2.2	5.2*	2.0	4.2*	6.3
	outriggers raised, on tyres	8.5	14.4*	4.7	7.4	3.0	4.7	2.8	4.2*	
	4 point outriggers down	11.5	14.4*	6.0	9.2*	3.9	5.2*	3.6	4.2*	
-3.0	outriggers raised, on rail	5.9	11.9*	3.3	5.7*			3.2	5.6*	4.5
	outriggers raised, on tyres	8.4	11.9*	4.5	5.7*			4.5	5.6*	
	4 point outriggers down	11.3	11.9*	5.7*	5.7*			5.6*	5.6*	
-4.5	outriggers raised, on rail									
	outriggers raised, on tyres									

Stick 2.05 m

m	Undercarriage	3.0 m		4.5 m		6.0 m		7.5 m		m	
9.0	outriggers raised, on rail										
	outriggers raised, on tyres										
	4 point outriggers down										
7.5	outriggers raised, on rail									4.1	4.2*
	outriggers raised, on tyres									4.2*	4.2*
	4 point outriggers down									4.2*	4.2*
6.0	outriggers raised, on rail			4.0	6.6*					2.5	3.4*
	outriggers raised, on tyres			5.4	6.6*					3.4*	3.4*
	4 point outriggers down			6.6*	6.6*					3.4*	3.4*
4.5	outriggers raised, on rail	7.0	9.1*	4.0	7.3*	2.5	6.0*			2.0	3.1*
	outriggers raised, on tyres	9.1*	9.1*	5.3	7.3*	3.3	5.1			2.7	3.1*
	4 point outriggers down	9.1*	9.1*	6.5	7.3*	4.2	6.0*			3.1*	3.1*
3.0	outriggers raised, on rail	6.8	10.6*	4.0	8.3*	2.5	6.3*			1.7	3.0*
	outriggers raised, on tyres	9.1	10.6*	5.2	7.7	3.3	5.1			2.4	3.0*
	4 point outriggers down	10.6*	10.6*	6.4	8.3*	4.2	6.3*			3.0*	3.0*
1.5	outriggers raised, on rail	6.7	12.3*	3.9	8.9*	2.4	6.6*			1.7	3.1*
	outriggers raised, on tyres	9.1	12.3*	5.2	7.6	3.3	5.0			2.3	3.1*
	4 point outriggers down	11.5	12.3*	6.4	8.9*	4.1	6.6*			3.0	3.1*
0	outriggers raised, on rail	6.2	13.9*	3.6	9.0*	2.3	6.6*			1.7	3.3*
	outriggers raised, on tyres	8.8	13.9*	4.9	7.8	3.1	4.8			2.4	3.3*
	4 point outriggers down	11.7	13.9*	6.3	9.0*	4.0	6.6*			3.1	3.3*
-1.5	outriggers raised, on rail	6.0	14.3*	3.4	9.2*	2.2	5.8*			1.9	3.9*
	outriggers raised, on tyres	8.5	14.3*	4.7	7.5	3.0	4.7			2.7	3.9*
	4 point outriggers down	11.5	14.3*	6.0	9.2*	3.9	5.8*			3.5	3.9*
-3.0	outriggers raised, on rail	5.9	12.8*	3.3	6.6*					2.8	5.0*
	outriggers raised, on tyres	8.4	12.8*	4.5	6.6*					4.0	5.0*
	4 point outriggers down	11.3	12.8*	5.9	6.6*					5.0*	5.0*
-4.5	outriggers raised, on rail										
	outriggers raised, on tyres										

Stick 2.25 m

m	Undercarriage	3.0 m		4.5 m		6.0 m		7.5 m		m
9.0	outriggers raised, on rail									
	outriggers raised, on tyres									
	4 point outriggers down									
7.5	outriggers raised, on rail			3.8	4.2*			3.6*	3.6*	4.6
	outriggers raised, on tyres			4.2*	4.2*			3.6*	3.6*	
	4 point outriggers down			4.2*	4.2*			3.6*	3.6*	
6.0	outriggers raised, on rail			4.1	6.0*	2.4	3.4*	2.4	2.9*	6.0
	outriggers raised, on tyres			5.4	6.0*	3.3	3.4*	2.9*	2.9*	
	4 point outriggers down			6.0*	6.0*	3.4*	3.4*	2.9*	2.9*	
4.5	outriggers raised, on rail	7.0	7.5*	4.0	7.0*	2.5	5.9*	1.9	2.7*	6.9
	outriggers raised, on tyres	7.5*	7.5*	5.3	7.0*	3.4	5.1	2.6	2.7*	
	4 point outriggers down	7.5*	7.5*	6.5	7.0*	4.2	5.9*	2.7*	2.7*	
3.0	outriggers raised, on rail	6.7	10.9*	3.9	8.1*	2.5	6.2*	1.7	2.7*	7.3
	outriggers raised, on tyres	9.1	10.9*	5.2	7.7	3.4	5.1	2.3	2.7*	
	4 point outriggers down	10.9*	10.9*	6.4	8.1*	4.2	6.2*	2.7*	2.7*	
1.5	outriggers raised, on rail	6.6	12.2*	3.9	8.8*	2.4	6.5*	1.6	2.8*	7.4
	outriggers raised, on tyres	9.0	12.2*	5.2	7.6	3.3	5.0	2.2	2.8*	
	4 point outriggers down	11.5	12.2*	6.4	8.8*	4.1	6.5*	2.8*	2.8*	
0	outriggers raised, on rail	6.3	13.8*	3.6	8.9*	2.3	6.6*	1.6	3.0*	7.2
	outriggers raised, on tyres	8.9	13.8*	4.9	7.7	3.1	4.8	2.3	3.0*	
	4 point outriggers down	11.6	13.8*	6.3	8.9*	4.0	6.6*	3.0	3.0*	
-1.5	outriggers raised, on rail	6.0	14.2*	3.4	9.2*	2.2	6.1*	1.8	3.5*	6.7
	outriggers raised, on tyres	8.5	14.2*	4.7	7.5	3.0	4.7	2.6	3.5*	
	4 point outriggers down	11.5	14.2*	6.1	9.2*	3.9	6.1*	3.3	3.5*	
-3.0	outriggers raised, on rail	5.8	13.5*	3.2	7.4*			2.5	4.5*	5.3
	outriggers raised, on tyres	8.4	13.5*	4.5	7.3			3.5	4.5*	
	4 point outriggers down	11.3	13.5*	5.9	7.4*			4.5	4.5*	
-4.5	outriggers raised, on rail									
	outriggers raised, on tyres									

Stick 2.65 m

m	Undercarriage	3.0 m		4.5 m		6.0 m		7.5 m		m	
9.0	outriggers raised, on rail									4.7*	4.7*
	outriggers raised, on tyres									4.7*	4.7*
	4 point outriggers down									4.7*	4.7*
7.5	outriggers raised, on rail							4.0	4.7*	2.8	2.8*
	outriggers raised, on tyres							4.7*	4.7*		
	4 point outriggers down							4.7*	4.7*	2.8*	2.8*
6.0	outriggers raised, on rail							4.1	4.9*	2.1	2.4*
	outriggers raised, on tyres							4.9*	4.9*		
	4 point outriggers down							4.9*	4.9*	2.4*	2.4*
4.5	outriggers raised, on rail	5.2*	5.2*	4.0	5.7*	2.6	5.3*			1.7	2.2*
	outriggers raised, on tyres	5.2*	5.2*	5.3	5.7*	3.4	5.1				
	4 point outriggers down	5.2*	5.2*	5.7*	5.7*	4.3	5.3*			2.2*	2.2*
3.0	outriggers raised, on rail	6.7	10.7*	3.9	7.7*	2.6	6.0*	1.6	3.7*	1.5	2.2*
	outriggers raised, on tyres	9.1	10.7*	5.2	7.6	3.4	5.1	2.2	3.5		
	4 point outriggers down	10.7*	10.7*	6.4	7.7*	4.3	6.0*	2.9	3.7*	2.2*	2.2*
1.5	outriggers raised, on rail	6.6	12.0*	3.9	8.6*	2.5	6.4*	1.6	4.5*	1.4	2.3*
	outriggers raised, on tyres	9.0	12.0*	5.1	7.5	3.3	5.0	2.2	3.4		
	4 point outriggers down	11.4	12.0*	6.3	8.6*	4.2	6.4*	2.8	4.5*	2.3*	2.3*
0	outriggers raised, on rail	6.3	13.3*	3.6	8.8*	2.3	6.5*	1.5	3.6*	1.5	2.4*
	outriggers raised, on tyres	8.9	13.3*	5.0	7.6	3.2	4.9	2.1	3.3		
	4 point outriggers down	11.5	13.3*	6.3	8.8*	4.0	6.5*	2.8	3.6*	2.4*	2.4*
-1.5	outriggers raised, on rail	6.0	14.0*	3.5	9.0*	2.2	6.4*			1.6	2.8*
	outriggers raised, on tyres	8.5	14.0*	4.8	7.6	3.0	4.7				
	4 point outriggers down	11.4	14.0*	6.1	9.0*	3.9	6.4*			2.8*	2.8*
-3.0	outriggers raised, on rail	5.9	14.3*	3.2	8.4*	2.1	4.0*			2.1	3.9*
	outriggers raised, on tyres	8.4	14.3*	4.5	7.3	2.9	4.0*				
	4 point outriggers down	11.4	14.3*	5.9	8.4*	3.8	4.0*			3.8	3.9*
-4.5	outriggers raised, on rail										
	outriggers raised, on tyres										

Height Can be slewed through 360° In longitudinal position of undercarriage Max. reach * Limited by hydr. capacity

The lift capacities are stated in metric tonnes (t) with PowerLift of 375 bar at the stick end without tools. This applies to a firm flat substrate with a closed steering axle. These capacities can be slewed through 360° with the undercarriage in the transverse position. Capacities in the longitudinal position of the undercarriage (+/- 15°) are specified over the steering axle with the stabilizers raised and over the rigid axle with the stabilizers down. The values apply when the adjusting cylinder is in the optimal position. Indicated loads based on the ISO 10567 standard and do not exceed 75% of tipping or 87% of hydraulic capacity, or are limited by the permissible load of the load lift hook.

In accordance with the harmonised European Standard EN 474-5, hydraulic excavators used for lifting operations must be equipped with pipe fracture safety valves, an overload warning device, a load lift hook and a lift capacity chart.

Please note that the stability will be reduced by approx. 20% in case of a 100 mm cant and 40% in case of a 200 mm cant.

Lift Capacities

with Two-Piece Boom 5.10 m (without Outriggers) with Tail Radius 2,050 mm

Stick 1.85 m

m	Undercarriage	3.0 m		4.5 m		6.0 m		7.5 m		m
9.0	on rail									
	on tyres									
7.5	on rail	7.3	7.9*						4.6	5.2*
	on tyres	7.9*	7.9*						5.2*	5.2*
6.0	on rail	6.7*	6.7*	4.0	6.9*				2.7	3.9*
	on tyres	6.7*	6.7*	5.3	6.9*				3.6	3.9*
4.5	on rail	7.1	10.3*	4.1	7.4*	2.5	6.2*		2.1	3.5*
	on tyres	9.4	10.3*	5.3	7.4*	3.3	5.0		2.8	3.5*
3.0	on rail	6.9	10.2*	4.0	8.4*	2.5	6.4*		1.8	3.4*
	on tyres	9.2	10.2*	5.3	7.7	3.3	5.0		2.5	3.4*
1.5	on rail	6.8	12.3*	3.9	8.9*	2.4	6.6*		1.8	3.4*
	on tyres	9.1	12.3*	5.2	7.7	3.2	4.9		2.4	3.4*
0	on rail	6.3	14.0*	3.7	9.0*	2.3	6.6*		1.8	3.7*
	on tyres	8.8	14.0*	5.0	7.8	3.1	4.8		2.5	3.7*
-1.5	on rail	6.1	14.4*	3.5	9.2*	2.2	5.2*		2.1	4.2*
	on tyres	8.6	14.4*	4.7	7.5	3.0	4.7		2.8	4.2*
-3.0	on rail	6.0	11.9*	3.3	5.7*				3.3	5.6*
	on tyres	8.5	11.9*	4.6	5.7*				4.5	5.6*
-4.5	on rail									
	on tyres									

Stick 2.05 m

m	Undercarriage	3.0 m		4.5 m		6.0 m		7.5 m		m
9.0	on rail									
	on tyres									
7.5	on rail								4.2	4.2*
	on tyres								4.2*	4.2*
6.0	on rail								2.6	3.4*
	on tyres								3.4*	3.4*
4.5	on rail	7.1	9.1*	4.1	7.3*	2.5	6.0*		2.0	3.1*
	on tyres	9.1*	9.1*	5.3	7.3*	3.4	5.1		2.7	3.1*
3.0	on rail	6.9	10.6*	4.0	8.3*	2.5	6.3*		1.8	3.0*
	on tyres	9.2	10.6*	5.3	7.7	3.4	5.1		2.4	3.0*
1.5	on rail	6.8	12.3*	3.9	8.9*	2.4	6.6*		1.7	3.1*
	on tyres	9.1	12.3*	5.2	7.7	3.3	5.0		2.3	3.1*
0	on rail	6.4	13.9*	3.7	9.0*	2.3	6.6*		1.8	3.3*
	on tyres	8.9	13.9*	5.0	7.8	3.1	4.8		2.4	3.3*
-1.5	on rail	6.1	14.3*	3.5	9.2*	2.2	5.8*		2.0	3.9*
	on tyres	8.6	14.3*	4.7	7.5	3.0	4.7		2.7	3.9*
-3.0	on rail	6.0	12.8*	3.3	6.6*				2.9	5.0*
	on tyres	8.5	12.8*	4.6	6.6*				4.0	5.0*
-4.5	on rail									
	on tyres									

Stick 2.25 m

m	Undercarriage	3.0 m		4.5 m		6.0 m		7.5 m		m
9.0	on rail									
	on tyres									
7.5	on rail			3.9	4.2*				3.6*	3.6*
	on tyres			4.2*	4.2*				3.6*	3.6*
6.0	on rail			4.1	6.0*	2.5	3.4*		2.4	2.9*
	on tyres			5.4	6.0*	3.3	3.4*		2.9*	2.9*
4.5	on rail	7.1	7.5*	4.1	7.0*	2.6	5.9*		1.9	2.7*
	on tyres	7.5*	7.5*	5.3	7.0*	3.4	5.1		2.6	2.7*
3.0	on rail	6.9	10.9*	4.0	8.1*	2.6	6.2*		1.7	2.7*
	on tyres	9.2	10.9*	5.2	7.7	3.4	5.1		2.3	2.7*
1.5	on rail	6.8	12.2*	4.0	8.8*	2.5	6.5*		1.6	2.8*
	on tyres	9.1	12.3*	5.2	7.6	3.3	5.0		2.2	2.8*
0	on rail	6.4	13.8*	3.7	8.9*	2.3	6.6*		1.7	3.0*
	on tyres	8.9	13.8*	5.0	7.7	3.2	4.8		2.3	3.0*
-1.5	on rail	6.1	14.2*	3.5	9.2*	2.2	6.1*		1.9	3.5*
	on tyres	8.6	14.2*	4.7	7.5	3.0	4.7		2.6	3.5*
-3.0	on rail	6.0	13.5*	3.3	7.4*				2.6	4.5*
	on tyres	8.4	13.5*	4.6	7.3				3.5	4.5*
-4.5	on rail									
	on tyres									

Stick 2.65 m

m	Undercarriage	3.0 m		4.5 m		6.0 m		7.5 m		m
9.0	on rail								4.7*	4.7*
	on tyres								4.7*	4.7*
7.5	on rail								2.8*	2.8*
	on tyres								2.8*	2.8*
6.0	on rail								2.2	2.4*
	on tyres								2.4*	2.4*
4.5	on rail	5.2*	5.2*	4.1	5.7*	2.6	5.3*		1.7	2.2*
	on tyres	5.2*	5.2*	5.3	5.7*	3.5	5.1		2.2*	2.2*
3.0	on rail	6.9	10.7*	4.0	7.7*	2.6	6.0*		1.5	2.2*
	on tyres	9.2	10.7*	5.2	7.7	3.4	5.1	1.6	2.3	3.5
1.5	on rail	6.7	12.0*	3.9	8.6*	2.5	6.4*	1.6	4.5*	1.5
	on tyres	9.0	12.0*	5.2	7.6	3.3	5.0	2.2	3.4	2.1
0	on rail	6.5	13.3*	3.7	8.8*	2.4	6.5*	1.5	3.6*	1.5
	on tyres	9.0	13.3*	5.0	7.6	3.2	4.9	2.2	3.4	2.1
-1.5	on rail	6.1	14.0*	3.5	9.0*	2.2	6.4*		1.7	2.8*
	on tyres	8.6	14.0*	4.8	7.6	3.0	4.7		2.3	2.8*
-3.0	on rail	6.0	14.3*	3.3	8.4*	2.1	4.0*		2.1	3.9*
	on tyres	8.5	14.3*	4.5	7.3	3.0	4.0*		2.9	3.9*
-4.5	on rail									
	on tyres									

Height Can be slewed through 360° In longitudinal position of undercarriage Max. reach * Limited by hydr. capacity

The lift capacities are stated in metric tonnes (t) with PowerLift of 375 bar at the stick end without tools. This applies to a firm flat substrate with a closed steering axle. These capacities can be slewed through 360° with the undercarriage in the transverse position. Capacities in the longitudinal position of the undercarriage (+/- 15°) are specified over the steering axle with the stabilizers raised. The values apply when the adjusting cylinder is in the optimal position. Indicated loads based on the ISO 10567 standard and do not exceed 75% of tipping or 87% of hydraulic capacity, or are limited by the permissible load of the load lift hook.

In accordance with the harmonised European Standard EN 474-5, hydraulic excavators used for lifting operations must be equipped with pipe fracture safety valves, an overload warning device, a load lift hook and a lift capacity chart.

Please note that the stability will be reduced by approx. 20% in case of a 100 mm cant and 40% in case of a 200 mm cant.

Lift Capacities

with Two-Piece Boom 5.10 m (4 Point Outriggers) with Tail Radius 2,050 mm

Stick 1.85 m

m	Undercarriage	3.0 m		4.5 m		6.0 m		7.5 m		m
9.0	outriggers raised, on rail									
	outriggers raised, on tyres 4 point outriggers down	7.7	7.9*					4.9	5.2*	
7.5	outriggers raised, on rail									
	outriggers raised, on tyres 4 point outriggers down	7.9*	7.9*					5.2*	5.2*	4.0
6.0	outriggers raised, on rail									
	outriggers raised, on tyres 4 point outriggers down	6.7*	6.7*	4.3	6.9*			2.9	3.9*	5.6
4.5	outriggers raised, on rail									
	outriggers raised, on tyres 4 point outriggers down	7.5	10.3*	4.3	7.4*	2.7	6.2*	2.3	3.5*	6.5
3.0	outriggers raised, on rail									
	outriggers raised, on tyres 4 point outriggers down	10.0	10.3*	5.6	7.4*	3.6	5.4	3.1	3.5*	7.0
1.5	outriggers raised, on rail									
	outriggers raised, on tyres 4 point outriggers down	7.2	12.3*	4.1	8.9*	2.6	6.6*	1.9	3.4*	7.1
0	outriggers raised, on rail									
	outriggers raised, on tyres 4 point outriggers down	9.6	12.3*	5.5	8.1	3.5	5.3	2.6	3.4*	6.9
-1.5	outriggers raised, on rail									
	outriggers raised, on tyres 4 point outriggers down	12.2	12.3*	6.8	8.9*	4.4	6.6*	3.3	3.4*	6.3
-3.0	outriggers raised, on rail									
	outriggers raised, on tyres 4 point outriggers down	6.7	14.0*	3.9	9.0*	2.5	6.6*	2.0	3.7*	4.5
-4.5	outriggers raised, on rail									
	outriggers raised, on tyres 4 point outriggers down	9.4	14.0*	5.3	8.2	3.4	5.1	2.7	3.7*	4.5

Stick 2.05 m

m	Undercarriage	3.0 m		4.5 m		6.0 m		7.5 m		m
9.0	outriggers raised, on rail									
	outriggers raised, on tyres 4 point outriggers down									4.2*
7.5	outriggers raised, on rail									4.2*
	outriggers raised, on tyres 4 point outriggers down									4.2*
6.0	outriggers raised, on rail									2.8
	outriggers raised, on tyres 4 point outriggers down			4.4	6.6*					3.4*
4.5	outriggers raised, on rail									2.2
	outriggers raised, on tyres 4 point outriggers down	7.5	9.1*	4.3	7.3*	2.7	6.0*	9.1*	9.1*	3.0
3.0	outriggers raised, on rail									1.9
	outriggers raised, on tyres 4 point outriggers down	9.7	10.6*	4.3	8.3*	2.7	6.3*	9.7	10.6*	2.6
1.5	outriggers raised, on rail									1.8
	outriggers raised, on tyres 4 point outriggers down	7.2	12.3*	4.2	8.9*	2.6	6.6*	9.6	12.3*	2.5
0	outriggers raised, on rail									3.1*
	outriggers raised, on tyres 4 point outriggers down	9.6	12.3*	5.6	8.0	3.5	5.3	12.2	12.3*	1.9
-1.5	outriggers raised, on rail									2.6
	outriggers raised, on tyres 4 point outriggers down	6.8	13.9*	4.0	9.0*	2.5	6.6*	9.5	13.9*	3.3*
-3.0	outriggers raised, on rail									2.1
	outriggers raised, on tyres 4 point outriggers down	6.5	14.3*	3.7	9.2*	2.4	5.8*	9.2	14.3*	2.9
-4.5	outriggers raised, on rail									3.7
	outriggers raised, on tyres 4 point outriggers down	12.3	14.3*	6.5	9.2*	4.2	5.8*	12.3	14.3*	3.1

Stick 2.25 m

m	Undercarriage	3.0 m		4.5 m		6.0 m		7.5 m		m
9.0	outriggers raised, on rail									
	outriggers raised, on tyres 4 point outriggers down							3.6*	3.6*	
7.5	outriggers raised, on rail									
	outriggers raised, on tyres 4 point outriggers down			4.2*	4.2*			3.6*	3.6*	4.6
6.0	outriggers raised, on rail									
	outriggers raised, on tyres 4 point outriggers down			4.4	6.0*	2.7	3.4*	2.6	2.9*	6.0
4.5	outriggers raised, on rail									
	outriggers raised, on tyres 4 point outriggers down	7.4	7.5*	4.3	7.0*	2.7	5.9*	2.1	2.7*	6.9
3.0	outriggers raised, on rail									
	outriggers raised, on tyres 4 point outriggers down	7.5*	7.5*	6.9	7.0*	4.5	5.9*	1.7	2.7*	7.3
1.5	outriggers raised, on rail									
	outriggers raised, on tyres 4 point outriggers down	7.3	10.9*	4.3	8.1*	2.7	6.2*	2.8	2.7*	7.4
0	outriggers raised, on rail									
	outriggers raised, on tyres 4 point outriggers down	9.7	10.9*	5.5	8.1*	3.6	5.4	2.5	2.7*	7.2
-1.5	outriggers raised, on rail									
	outriggers raised, on tyres 4 point outriggers down	10.9*	10.9*	6.8	8.1*	4.5	6.2*	2.7	2.7*	6.7
-3.0	outriggers raised, on rail									
	outriggers raised, on tyres 4 point outriggers down	7.2	12.2*	4.2	8.8*	2.6	6.5*	1.8	2.8*	5.3
-4.5	outriggers raised, on rail									
	outriggers raised, on tyres 4 point outriggers down	9.6	12.3*	5.5	8.0	3.5	5.3	2.4	2.8*	4.5

Stick 2.65 m

m	Undercarriage	3.0 m		4.5 m		6.0 m		7.5 m		m
9.0	outriggers raised, on rail									4.7*
	outriggers raised, on tyres 4 point outriggers down									4.7*
7.5	outriggers raised, on rail									2.8*
	outriggers raised, on tyres 4 point outriggers down			4.3	4.7*			4.7*	4.7*	5.2
6.0	outriggers raised, on rail									2.3
	outriggers raised, on tyres 4 point outriggers down			4.4	4.9*	2.7	4.3*	4.9*	4.9*	6.5
4.5	outriggers raised, on rail									1.9
	outriggers raised, on tyres 4 point outriggers down	5.2*	5.2*	4.3	5.7*	2.8	5.3*	5.2*	5.2*	7.3
3.0	outriggers raised, on rail									1.7
	outriggers raised, on tyres 4 point outriggers down	7.3	10.7*	4.2	7.7*	2.8	6.0*	1.8	3.7*	7.7
1.5	outriggers raised, on rail									1.6
	outriggers raised, on tyres 4 point outriggers down	9.7	10.7*	5.5	7.7*	3.7	5.4	2.4	3.7*	7.8
0	outriggers raised, on rail									2.2*
	outriggers raised, on tyres 4 point outriggers down	10.7*	10.7*	6.8	7.7*	4.6	6.0*	3.1	3.7*	7.6
-1.5	outriggers raised, on rail									1.8
	outriggers raised, on tyres 4 point outriggers down	7.1	12.0*	4.2	8.6*	2.7	6.4*	1.7	4.5*	7.1
-3.0	outriggers raised, on rail									2.5
	outriggers raised, on tyres 4 point outriggers down	9.5	12.0*	5.5	7.9	3.6	5.3	2.4	3.7	2.8*
-4.5	outriggers raised, on rail									2.3
	outriggers raised, on tyres 4 point outriggers down	12.0	12.0*	6.7	8.6*	4.5	6.4*	3.0	4.5*	6.0

Height Can be slewed through 360° In longitudinal position of undercarriage Max. reach * Limited by hydr. capacity

The lift capacities are stated in metric tonnes (t) with PowerLift of 375 bar at the stick end without tools. This applies to a firm flat substrate with a closed steering axle. These capacities can be slewed through 360° with the undercarriage in the transverse position. Capacities in the longitudinal position of the undercarriage (+/- 15°) are specified over the steering axle with the stabilizers raised and over the rigid axle with the stabilizers down. The values apply when the adjusting cylinder is in the optimal position. Indicated loads based on the ISO 10567 standard and do not exceed 75% of tipping or 87% of hydraulic capacity, or are limited by the permissible load of the load lift hook.

In accordance with the harmonised European Standard EN 474-5, hydraulic excavators used for lifting operations must be equipped with pipe fracture safety valves, an overload warning device, a load lift hook and a lift capacity chart.

Please note that the stability will be reduced by approx. 20% in case of a 100 mm cant and 40% in case of a 200 mm cant.

Lift Capacities

with Offset Two-Piece Boom 5.25 m (without Outriggers) with Tail Radius 2,000 mm

Stick 1.85 m

m	Undercarriage	3.0 m		4.5 m		6.0 m		7.5 m		m
9.0	on rail									
	on tyres									
7.5	on rail	6.9	7.6*						3.6	4.5*
	on tyres	7.6*	7.6*						4.5*	4.5*
6.0	on rail	6.8	6.8*	3.7	6.5*				2.1	3.5*
	on tyres	6.8*	6.8*	4.9	6.5*				3.0	3.5*
4.5	on rail	6.4	9.5*	3.6	7.1*	2.1	5.8*		1.6	3.2*
	on tyres	8.7	9.5*	4.9	7.1*	2.9	4.6		2.3	3.2*
3.0	on rail	6.1	9.3*	3.6	8.0*	2.1	6.0*		1.3	3.1*
	on tyres	8.3	9.3*	4.8	7.0	2.9	4.6		2.0	3.1*
1.5	on rail	6.0	11.4*	3.5	8.4*	2.0	6.2*		1.3	3.2*
	on tyres	8.3	11.4*	4.7	7.0	2.8	4.5		1.9	3.1
0	on rail	5.5	13.3*	3.2	8.5*	1.8	6.3*		1.3	3.4*
	on tyres	7.9	13.3	4.4	7.2	2.6	4.3		1.9	3.2
-1.5	on rail	5.2	13.8*	2.9	8.9*	1.7	5.4*		1.5	3.9*
	on tyres	7.6	13.8	4.1	6.8	2.5	4.1		2.2	3.7
-3.0	on rail	5.1	12.4*	2.7	6.3*				2.3	4.6*
	on tyres	7.5	12.4*	3.9	6.3*				3.3	4.6*
-4.5	on rail									
	on tyres									

Stick 2.05 m

m	Undercarriage	3.0 m		4.5 m		6.0 m		7.5 m		m	
9.0	on rail										
	on tyres										
7.5	on rail			3.5	4.5*					3.3	3.7*
	on tyres			4.5*	4.5*					3.7*	3.7*
6.0	on rail			3.7	6.3*	2.1	3.7*			2.0	3.1*
	on tyres			5.0	6.3*	2.9	3.7*			2.8	3.1*
4.5	on rail	6.5	9.8*	3.7	6.9*	2.2	5.7*			1.5	2.8*
	on tyres	8.8	9.8*	4.9	6.9*	3.0	4.7			2.2	2.8*
3.0	on rail	6.1	9.8*	3.6	7.9*	2.2	6.0*			1.3	2.8*
	on tyres	8.3	9.8*	4.8	7.0	3.0	4.6			1.9	2.8*
1.5	on rail	6.0	11.5*	3.5	8.4*	2.1	6.2*			1.2	2.9*
	on tyres	8.3	11.5*	4.8	7.0	2.9	4.5			1.8	2.9*
0	on rail	5.5	13.2*	3.2	8.5*	1.9	6.3*			1.2	3.1*
	on tyres	7.9	13.2*	4.4	7.2	2.7	4.3			1.9	3.1*
-1.5	on rail	5.2	13.7*	2.9	8.9*	1.7	5.8*			1.4	3.6*
	on tyres	7.6	13.7	4.2	6.8	2.5	4.2			2.1	3.5
-3.0	on rail	5.1	13.1*	2.7	7.0*					2.1	4.2*
	on tyres	7.5	13.1*	3.9	6.6					3.0	4.2*
-4.5	on rail										
	on tyres										

Stick 2.25 m

m	Undercarriage	3.0 m		4.5 m		6.0 m		7.5 m		m	
9.0	on rail										
	on tyres										
7.5	on rail			3.6	4.9*					3.0	3.2*
	on tyres			4.8	4.9*					3.2*	3.2*
6.0	on rail			3.8	6.0*	2.1	4.3*			1.9	2.7*
	on tyres			5.0	6.0*	2.9	4.3*			2.7	2.7*
4.5	on rail	6.5	9.4*	3.7	6.7*	2.2	5.5*			1.5	2.5*
	on tyres	8.8	9.4*	4.9	6.7*	3.0	4.7			2.1	2.5*
3.0	on rail	6.1	10.1*	3.5	7.7*	2.2	5.9*			1.2	2.5*
	on tyres	8.3	10.1*	4.8	7.0	3.0	4.7			1.8	2.5*
1.5	on rail	6.0	11.4*	3.5	8.4*	2.1	6.1*	1.2	3.8*	1.2	2.6*
	on tyres	8.2	11.4*	4.7	7.0	2.9	4.6	1.8	3.0	1.7	2.6*
0	on rail	5.6	13.0*	3.2	8.4*	1.9	6.2*			1.2	2.8*
	on tyres	8.0	13.0*	4.5	7.1	2.7	4.4			1.8	2.8*
-1.5	on rail	5.2	13.6*	3.0	8.7*	1.7	6.0*			1.3	3.3*
	on tyres	7.6	13.5	4.2	6.9	2.5	4.2			2.0	3.3*
-3.0	on rail	5.1	13.6*	2.7	7.6*					1.8	3.9*
	on tyres	7.5	13.6*	3.9	6.6					2.7	3.9*
-4.5	on rail										
	on tyres										

Stick 2.65 m

m	Undercarriage	3.0 m		4.5 m		6.0 m		7.5 m		m	
9.0	on rail	4.1*	4.1*							3.8*	3.8*
	on tyres	4.1*	4.1*							3.8*	3.8*
7.5	on rail			3.7	4.7*					2.5	2.5*
	on tyres			4.7*	4.7*					2.5*	2.5*
6.0	on rail			3.8	5.0*	2.2	4.5*			1.7	2.2*
	on tyres			5.0*	5.0*	3.1	4.5*			2.2*	2.2*
4.5	on rail	5.9*	5.9*	3.7	6.1*	2.3	5.3*			1.3	2.0*
	on tyres	5.9*	5.9*	4.9	6.1*	3.1	4.7			1.9	2.0*
3.0	on rail	6.1	10.0*	3.5	7.4*	2.3	5.7*	1.3	4.2*	1.1	2.0*
	on tyres	8.4	10.0*	4.8	7.0	3.1	4.6	1.9	3.1	1.7	2.0*
1.5	on rail	5.9	11.2*	3.5	8.2*	2.2	6.0*	1.2	4.8*	1.0	2.1*
	on tyres	8.1	11.2*	4.7	6.9	3.0	4.6	1.8	3.0	1.6	2.1*
0	on rail	5.6	12.6*	3.2	8.3*	2.0	6.1*	1.1	4.5*	1.0	2.3*
	on tyres	8.1	12.6*	4.5	7.0	2.8	4.4	1.7	2.9	1.6	2.3*
-1.5	on rail	5.2	13.4*	3.0	8.5*	1.8	6.2*			1.2	2.6*
	on tyres	7.6	13.3	4.2	7.0	2.6	4.2			1.8	2.6*
-3.0	on rail	5.2	14.0*	2.7	8.3*	1.6	4.4*			1.5	3.3*
	on tyres	7.5	14.0	3.9	6.6	2.4	4.1			2.2	3.3*
-4.5	on rail									6.6	10.6*
	on tyres									10.0	10.6*

Height Can be slewed through 360° In longitudinal position of undercarriage Max. reach * Limited by hydr. capacity

The lift capacities are stated in metric tonnes (t) with PowerLift of 375 bar at the stick end without tools. This applies to a firm flat substrate with a closed steering axle. These capacities can be slewed through 360° with the undercarriage in the transverse position. Capacities in the longitudinal position of the undercarriage (+/- 15°) are specified over the steering axle with the stabilizers raised. The values apply when the adjusting cylinder is in the optimal position. Indicated loads based on the ISO 10567 standard and do not exceed 75% of tipping or 87% of hydraulic capacity, or are limited by the permissible load of the load lift hook.

In accordance with the harmonised European Standard EN 474-5, hydraulic excavators used for lifting operations must be equipped with pipe fracture safety valves, an overload warning device, a load lift hook and a lift capacity chart.

Please note that the stability will be reduced by approx. 20% in case of a 100 mm cant and 50% in case of a 200 mm cant.

Lift Capacities

with Offset Two-Piece Boom 5.25 m (4 Point Outriggers) with Tail Radius 2,000 mm

Stick 1.85 m

m	Undercarriage	3.0 m		4.5 m		6.0 m		7.5 m		m
9.0	outriggers raised, on rail outriggers raised, on tyres 4 point outriggers down									
7.5	outriggers raised, on rail outriggers raised, on tyres 4 point outriggers down	7.3	7.6*					3.9	4.5*	4.3
6.0	outriggers raised, on rail outriggers raised, on tyres 4 point outriggers down	6.8*	6.8*	3.9	6.5*			2.3	3.5*	5.8
4.5	outriggers raised, on rail outriggers raised, on tyres 4 point outriggers down	6.8	9.5*	3.9	7.1*	2.3	5.8*	1.7	3.2*	6.7
3.0	outriggers raised, on rail outriggers raised, on tyres 4 point outriggers down	6.5	9.3*	3.8	8.0*	2.3	6.0*	1.5	3.1*	7.2
1.5	outriggers raised, on rail outriggers raised, on tyres 4 point outriggers down	6.4	11.4*	3.7	8.4*	2.2	6.2*	1.4	3.2*	7.3
0	outriggers raised, on rail outriggers raised, on tyres 4 point outriggers down	5.9	13.3*	3.4	8.5*	2.0	6.3*	1.4	3.4*	7.0
-1.5	outriggers raised, on rail outriggers raised, on tyres 4 point outriggers down	5.6	13.8*	3.1	8.9*	1.9	5.4*	1.6	3.9*	6.5
-3.0	outriggers raised, on rail outriggers raised, on tyres 4 point outriggers down	5.5	12.4*	3.0	6.3*			2.5	4.6*	5.0
-4.5	outriggers raised, on rail outriggers raised, on tyres 4 point outriggers down	8.1	12.4*	4.3	6.3*			3.6	4.6*	

Stick 2.05 m

m	Undercarriage	3.0 m		4.5 m		6.0 m		7.5 m		m
9.0	outriggers raised, on rail outriggers raised, on tyres 4 point outriggers down									
7.5	outriggers raised, on rail outriggers raised, on tyres 4 point outriggers down			3.7	4.5*					4.6
6.0	outriggers raised, on rail outriggers raised, on tyres 4 point outriggers down			4.0	6.3*	2.2	3.7*			6.1
4.5	outriggers raised, on rail outriggers raised, on tyres 4 point outriggers down	6.9	9.8*	3.9	6.9*	2.3	5.7*	1.7	2.8*	6.9
3.0	outriggers raised, on rail outriggers raised, on tyres 4 point outriggers down	6.5	9.8*	3.8	7.9*	2.3	6.0*	1.4	2.8*	7.3
1.5	outriggers raised, on rail outriggers raised, on tyres 4 point outriggers down	6.4	11.5*	3.7	8.4*	2.2	6.2*	1.4	2.9*	7.4
0	outriggers raised, on rail outriggers raised, on tyres 4 point outriggers down	5.9	13.2*	3.4	8.5*	2.1	6.3*	1.4	3.1*	7.2
-1.5	outriggers raised, on rail outriggers raised, on tyres 4 point outriggers down	5.6	13.7*	3.2	8.9*	1.9	5.8*	1.6	3.6*	6.7
-3.0	outriggers raised, on rail outriggers raised, on tyres 4 point outriggers down	5.5	13.1*	3.0	7.0*			2.2	4.2*	5.3
-4.5	outriggers raised, on rail outriggers raised, on tyres 4 point outriggers down	8.1	13.1*	4.3	7.0*			3.3	4.2*	

Stick 2.25 m

m	Undercarriage	3.0 m		4.5 m		6.0 m		7.5 m		m
9.0	outriggers raised, on rail outriggers raised, on tyres 4 point outriggers down									
7.5	outriggers raised, on rail outriggers raised, on tyres 4 point outriggers down			3.8	4.9*			3.2*	3.2*	4.9
6.0	outriggers raised, on rail outriggers raised, on tyres 4 point outriggers down			4.0	6.0*	2.3	4.3*	2.1	2.7*	6.3
4.5	outriggers raised, on rail outriggers raised, on tyres 4 point outriggers down	6.9	9.4*	3.9	6.7*	2.4	5.5*	1.6	2.5*	7.1
3.0	outriggers raised, on rail outriggers raised, on tyres 4 point outriggers down	6.5	10.1*	3.8	7.7*	2.4	5.9*	1.4	2.5*	7.5
1.5	outriggers raised, on rail outriggers raised, on tyres 4 point outriggers down	6.4	11.4*	3.8	8.4*	2.3	6.1*	1.3	2.6*	7.6
0	outriggers raised, on rail outriggers raised, on tyres 4 point outriggers down	6.0	13.0*	3.5	8.4*	2.1	6.2*	1.3	2.8*	7.4
-1.5	outriggers raised, on rail outriggers raised, on tyres 4 point outriggers down	5.6	13.6*	3.2	8.7*	1.9	6.0*	1.5	3.3*	6.8
-3.0	outriggers raised, on rail outriggers raised, on tyres 4 point outriggers down	5.5	13.6*	2.9	7.6*			2.0	3.9*	5.5
-4.5	outriggers raised, on rail outriggers raised, on tyres 4 point outriggers down	8.1	13.6*	4.2	7.1			3.0	3.9*	

Stick 2.65 m

m	Undercarriage	3.0 m		4.5 m		6.0 m		7.5 m		m
9.0	outriggers raised, on rail outriggers raised, on tyres 4 point outriggers down	4.1*	4.1*					3.8*	3.8*	3.1
7.5	outriggers raised, on rail outriggers raised, on tyres 4 point outriggers down			4.0	4.7*			2.5*	2.5*	5.5
6.0	outriggers raised, on rail outriggers raised, on tyres 4 point outriggers down			4.0	5.0*	2.4	4.5*	1.8	2.2*	6.7
4.5	outriggers raised, on rail outriggers raised, on tyres 4 point outriggers down	5.9*	5.9*	3.9	6.1*	2.5	5.3*	1.4	2.0*	7.5
3.0	outriggers raised, on rail outriggers raised, on tyres 4 point outriggers down	6.5	10.0*	3.8	7.4*	2.5	5.7*	1.4	2.2*	7.9
1.5	outriggers raised, on rail outriggers raised, on tyres 4 point outriggers down	6.3	11.2*	3.7	8.2*	2.4	6.0*	1.4	4.8*	8.0
0	outriggers raised, on rail outriggers raised, on tyres 4 point outriggers down	6.0	12.6*	3.5	8.3*	2.2	6.1*	1.3	4.5*	7.8
-1.5	outriggers raised, on rail outriggers raised, on tyres 4 point outriggers down	5.6	13.4*	3.2	8.5*	1.9	6.2*	1.3	2.6*	7.3
-3.0	outriggers raised, on rail outriggers raised, on tyres 4 point outriggers down	5.6	14.0*	2.9	8.3*	1.8	4.4*	1.6	3.3*	6.3
-4.5	outriggers raised, on rail outriggers raised, on tyres 4 point outriggers down	8.1	14.0*	4.3	7.1	2.7	4.4*	2.4	3.3*	2.5

Height Can be slewed through 360° In longitudinal position of undercarriage Max. reach * Limited by hydr. capacity

The lift capacities are stated in metric tonnes (t) with PowerLift of 375 bar at the stick end without tools. This applies to a firm flat substrate with a closed steering axle. These capacities can be slewed through 360° over the undercarriage in the transverse position. Capacities in the longitudinal position of the undercarriage (+/- 15°) are specified over the steering axle with the stabilizers raised and over the rigid axle with the stabilizers down. The values apply when the adjusting cylinder is in the optimal position. Indicated loads based on the ISO 10567 standard and do not exceed 75% of tipping or 87% of hydraulic capacity, or are limited by the permissible load of the load lift hook.

In accordance with the harmonised European Standard EN 474-5, hydraulic excavators used for lifting operations must be equipped with pipe fracture safety valves, an overload warning device, a load lift hook and a lift capacity chart.

Please note that the stability will be reduced by approx. 20% in case of a 100 mm cant and 50% in case of a 200 mm cant.

Lift Capacities

with Offset Two-Piece Boom 5.25 m (without Outriggers) with Tail Radius 2,050 mm

Stick 1.85 m

m	Undercarriage	3.0 m		4.5 m		6.0 m		7.5 m		m	
9.0	on rail										
	on tyres										
7.5	on rail	7.4	7.6*					4.0	4.5*	4.3	
	on tyres	7.6*	7.6*					4.5*	4.5*		
6.0	on rail	6.8*	6.8*	4.0	6.5*			2.3	3.5*	5.8	
	on tyres	6.8*	6.8*	5.3	6.5*			3.2	3.5*		
4.5	on rail	7.0	9.5*	4.0	7.1*	2.3	5.8*		1.8	3.2*	6.7
	on tyres	9.2	9.5*	5.2	7.1*	3.2	4.9		2.5	3.2*	
3.0	on rail	6.6	9.3*	3.9	8.0*	2.3	6.0*		1.5	3.1*	7.2
	on tyres	8.8	9.3*	5.1	7.4	3.2	4.9		2.2	3.1*	
1.5	on rail	6.6	11.4*	3.8	8.4*	2.2	6.2*		1.4	3.2*	7.3
	on tyres	8.8	11.4*	5.1	7.4	3.1	4.8		2.1	3.2*	
0	on rail	6.0	13.3*	3.5	8.5*	2.1	6.3*		1.5	3.4*	7.0
	on tyres	8.5	13.3*	4.8	7.6	2.9	4.6		2.2	3.4*	
-1.5	on rail	5.8	13.8*	3.2	8.9*	1.9	5.4*		1.7	3.9*	6.5
	on tyres	8.3	13.8*	4.5	7.3	2.8	4.5		2.4	3.9*	
-3.0	on rail	5.6	12.4*	3.0	6.3*				2.6	4.6*	5.0
	on tyres	8.1	12.4*	4.3	6.3*				3.7	4.6*	
-4.5	on rail										
	on tyres										

Stick 2.05 m

m	Undercarriage	3.0 m		4.5 m		6.0 m		7.5 m		m	
9.0	on rail										
	on tyres										
7.5	on rail										
	on tyres			3.8	4.5*				3.6	3.7*	4.6
6.0	on rail										
	on tyres			4.5*	4.5*				3.7*	3.7*	
6.0	on rail										
	on tyres			4.1	6.3*	2.3	3.7*		2.2	3.1*	6.1
4.5	on rail	7.0	9.8*	4.0	6.9*	2.4	5.7*		1.7	2.8*	
	on tyres	9.3	9.8*	5.2	6.9*	3.3	5.0		2.4	2.8*	
3.0	on rail	6.7	9.8*	3.9	7.9*	2.4	6.0*		1.5	2.8*	7.3
	on tyres	8.9	9.8*	5.1	7.4	3.2	5.0		2.1	2.8*	
1.5	on rail	6.6	11.5*	3.8	8.4*	2.3	6.2*		1.4	2.9*	7.4
	on tyres	8.8	11.5*	5.1	7.4	3.1	4.9		2.0	2.9*	
0	on rail	6.1	13.2*	3.5	8.5*	2.1	6.3*		1.4	3.1*	7.2
	on tyres	8.6	13.2*	4.8	7.5	3.0	4.7		2.1	3.1*	
-1.5	on rail	5.8	13.7*	3.3	8.9*	2.0	5.8*		1.6	3.6*	6.7
	on tyres	8.3	13.7*	4.5	7.3	2.8	4.5		2.3	3.6*	
-3.0	on rail	5.7	13.1*	3.0	7.0*				2.3	4.2*	5.3
	on tyres	8.1	13.1*	4.3	7.0*				3.3	4.2*	
-4.5	on rail										
	on tyres										

Stick 2.25 m

m	Undercarriage	3.0 m		4.5 m		6.0 m		7.5 m		m		
9.0	on rail											
	on tyres											
7.5	on rail											
	on tyres			3.9	4.9*				3.2*	3.2*	4.9	
6.0	on rail											
	on tyres			4.9*	4.9*				3.2*	3.2*		
6.0	on rail											
	on tyres			4.1	6.0*	2.4	4.3*		2.1	2.7*	6.3	
4.5	on rail	7.0	9.4*	4.0	6.7*	2.5	5.5*		1.6	2.5*		7.1
	on tyres	9.3	9.4*	5.2	6.7*	3.3	5.0		2.3	2.5*		
3.0	on rail	6.7	10.1*	3.9	7.7*	2.4	5.9*		1.4	2.5*	7.5	
	on tyres	8.9	10.1*	5.1	7.4	3.3	5.0		2.0	2.5*		
1.5	on rail	6.5	11.4*	3.8	8.4*	2.3	6.1*	1.4	3.8*	1.3	2.6*	7.6
	on tyres	8.7	11.4*	5.1	7.3	3.2	4.9	2.0	3.2	1.9	2.6*	
0	on rail	6.1	13.0*	3.5	8.4*	2.1	6.2*		1.4	2.8*	7.4	
	on tyres	8.6	13.0*	4.8	7.5	3.0	4.7		2.0	2.8*		
-1.5	on rail	5.8	13.6*	3.3	8.7*	2.0	6.0*		1.5	3.3*	6.8	
	on tyres	8.3	13.6*	4.6	7.4	2.8	4.5		2.2	3.3*		
-3.0	on rail	5.7	13.6*	3.0	7.6*				2.1	3.9*	5.5	
	on tyres	8.1	13.6*	4.3	7.1				3.0	3.9*		
-4.5	on rail											
	on tyres											

Stick 2.65 m

m	Undercarriage	3.0 m		4.5 m		6.0 m		7.5 m		m		
9.0	on rail											
	on tyres											
7.5	on rail											
	on tyres			4.1	4.7*				3.8*	3.8*	3.1	
6.0	on rail											
	on tyres			4.1*	4.1*				3.8*	3.8*		
6.0	on rail											
	on tyres			4.1	4.7*				2.5*	2.5*	5.5	
6.0	on rail											
	on tyres			4.1	5.0*	2.5	4.5*		1.9	2.2*	6.7	
4.5	on rail	5.9*	5.9*	4.0	6.1*	2.6	5.3*		1.5	2.0*		7.5
	on tyres	5.9*	5.9*	5.2	6.1*	3.4	5.0		2.0*	2.0*		
3.0	on rail	6.7	10.0*	3.8	7.4*	2.5	5.7*	1.5	4.2*	1.3	2.0*	7.9
	on tyres	8.9	10.0*	5.1	7.4*	3.4	4.9	2.1	3.3	1.9	2.0*	
1.5	on rail	6.5	11.2*	3.8	8.2*	2.4	6.0*	1.4	4.8*	1.2	2.1*	8.0
	on tyres	8.7	11.2*	5.0	7.3	3.3	4.9	2.0	3.3	1.8	2.1*	
0	on rail	6.2	12.6*	3.6	8.3*	2.2	6.1*	1.3	4.5*	1.2	2.3*	7.8
	on tyres	8.7	12.6*	4.9	7.3	3.1	4.8	1.9	3.2	1.8	2.3*	
-1.5	on rail	5.7	13.4*	3.3	8.5*	2.0	6.2*		1.3	2.6*	7.3	
	on tyres	8.2	13.4*	4.6	7.5	2.8	4.5		2.0	2.6*		
-3.0	on rail	5.7	14.0*	3.0	8.3*	1.9	4.4*		1.7	3.3*	6.3	
	on tyres	8.2	14.0*	4.3	7.1	2.7	4.4*		2.5	3.3*		
-4.5	on rail											
	on tyres								7.3	10.6*		2.5
									10.6*	10.6*		

Height Can be slewed through 360° In longitudinal position of undercarriage Max. reach * Limited by hydr. capacity

The lift capacities are stated in metric tonnes (t) with PowerLift of 375 bar at the stick end without tools. This applies to a firm flat substrate with a closed steering axle. These capacities can be slewed through 360° with the undercarriage in the transverse position. Capacities in the longitudinal position of the undercarriage (+/- 15°) are specified over the steering axle with the stabilizers raised. The values apply when the adjusting cylinder is in the optimal position. Indicated loads based on the ISO 10567 standard and do not exceed 75% of tipping or 87% of hydraulic capacity, or are limited by the permissible load of the load lift hook.

In accordance with the harmonised European Standard EN 474-5, hydraulic excavators used for lifting operations must be equipped with pipe fracture safety valves, an overload warning device, a load lift hook and a lift capacity chart.

Please note that the stability will be reduced by approx. 20% in case of a 100 mm cant and 50% in case of a 200 mm cant.

Lift Capacities

with Offset Two-Piece Boom 5.25 m (4 Point Outriggers) with Tail Radius 2,050 mm

Stick 1.85 m

m	Undercarriage	3.0 m		4.5 m		6.0 m		7.5 m		m
9.0	outriggers raised, on rail outriggers raised, on tyres 4 point outriggers down									
7.5	outriggers raised, on rail outriggers raised, on tyres 4 point outriggers down	7.6*	7.6*						4.2	4.5*
6.0	outriggers raised, on rail outriggers raised, on tyres 4 point outriggers down	6.8*	6.8*	4.2	6.5*				2.5	3.5*
4.5	outriggers raised, on rail outriggers raised, on tyres 4 point outriggers down	7.3	9.5*	4.2	7.1*	2.5	5.8*		1.9	3.2*
3.0	outriggers raised, on rail outriggers raised, on tyres 4 point outriggers down	7.0	9.3*	4.1	8.0*	2.5	6.0*		1.7	3.1*
1.5	outriggers raised, on rail outriggers raised, on tyres 4 point outriggers down	7.0	11.4*	4.0	8.4*	2.4	6.2*		1.6	3.2*
0	outriggers raised, on rail outriggers raised, on tyres 4 point outriggers down	6.4	13.3*	3.7	8.5*	2.2	6.3*		1.6	3.4*
-1.5	outriggers raised, on rail outriggers raised, on tyres 4 point outriggers down	6.2	13.8*	3.5	8.9*	2.1	5.4*		1.9	3.9*
-3.0	outriggers raised, on rail outriggers raised, on tyres 4 point outriggers down	6.0	12.4*	3.3	6.3*				2.8	4.6*
-4.5	outriggers raised, on rail outriggers raised, on tyres 4 point outriggers down	8.7	12.4*	4.6	6.3*				4.0	4.6*

Stick 2.05 m

m	Undercarriage	3.0 m		4.5 m		6.0 m		7.5 m		m
9.0	outriggers raised, on rail outriggers raised, on tyres 4 point outriggers down									
7.5	outriggers raised, on rail outriggers raised, on tyres 4 point outriggers down			4.0	4.5*					3.7*
6.0	outriggers raised, on rail outriggers raised, on tyres 4 point outriggers down			4.3	6.3*	2.5	3.7*			2.4
4.5	outriggers raised, on rail outriggers raised, on tyres 4 point outriggers down	7.4	9.8*	4.2	6.9*	2.6	5.7*			1.9
3.0	outriggers raised, on rail outriggers raised, on tyres 4 point outriggers down	9.8	9.8*	4.1	7.9*	2.6	6.0*			1.6
1.5	outriggers raised, on rail outriggers raised, on tyres 4 point outriggers down	7.0	11.5*	4.1	8.4*	2.5	6.2*			1.5
0	outriggers raised, on rail outriggers raised, on tyres 4 point outriggers down	9.3	9.8*	5.4	7.8	3.5	5.2			2.3
-1.5	outriggers raised, on rail outriggers raised, on tyres 4 point outriggers down	6.2	13.7*	3.5	8.9*	2.1	5.8*			1.8
-3.0	outriggers raised, on rail outriggers raised, on tyres 4 point outriggers down	6.1	13.1*	3.3	7.0*					2.5
-4.5	outriggers raised, on rail outriggers raised, on tyres 4 point outriggers down	8.7	13.1*	4.6	7.0*					3.6

Stick 2.25 m

m	Undercarriage	3.0 m		4.5 m		6.0 m		7.5 m		m
9.0	outriggers raised, on rail outriggers raised, on tyres 4 point outriggers down									
7.5	outriggers raised, on rail outriggers raised, on tyres 4 point outriggers down			4.1	4.9*				3.2*	3.2*
6.0	outriggers raised, on rail outriggers raised, on tyres 4 point outriggers down			4.3	6.0*	2.5	4.3*		2.3	2.7*
4.5	outriggers raised, on rail outriggers raised, on tyres 4 point outriggers down	7.4	9.4*	4.2	6.7*	2.6	5.5*		1.8	2.5*
3.0	outriggers raised, on rail outriggers raised, on tyres 4 point outriggers down	9.4*	9.4*	5.5	6.7*	3.5	5.3		2.5*	2.5*
1.5	outriggers raised, on rail outriggers raised, on tyres 4 point outriggers down	7.0	10.1*	4.1	7.7*	2.6	5.9*		1.6	2.5*
0	outriggers raised, on rail outriggers raised, on tyres 4 point outriggers down	9.3	10.1*	5.4	7.7*	3.5	5.2		2.2	2.5*
-1.5	outriggers raised, on rail outriggers raised, on tyres 4 point outriggers down	6.9	11.4*	4.1	8.4*	2.5	6.1*	1.5	3.8*	1.5
-3.0	outriggers raised, on rail outriggers raised, on tyres 4 point outriggers down	9.2	13.0*	5.2	7.8*	3.2	5.0*		2.2	2.8*
-4.5	outriggers raised, on rail outriggers raised, on tyres 4 point outriggers down	11.8	13.0*	6.6	8.4*	4.1	6.2*		2.8*	2.8*

Stick 2.65 m

m	Undercarriage	3.0 m		4.5 m		6.0 m		7.5 m		m
9.0	outriggers raised, on rail outriggers raised, on tyres 4 point outriggers down	4.1*	4.1*							3.8*
7.5	outriggers raised, on rail outriggers raised, on tyres 4 point outriggers down	4.1*	4.1*							3.8*
6.0	outriggers raised, on rail outriggers raised, on tyres 4 point outriggers down			4.3	4.7*					2.5*
4.5	outriggers raised, on rail outriggers raised, on tyres 4 point outriggers down	5.9*	5.9*	4.2	6.1*	2.7	5.3*			2.0*
3.0	outriggers raised, on rail outriggers raised, on tyres 4 point outriggers down	7.1	10.0*	4.1	7.4*	2.7	5.7*	1.6	4.2*	1.4
1.5	outriggers raised, on rail outriggers raised, on tyres 4 point outriggers down	9.4	10.0*	5.4	7.4*	3.6	5.2	2.3	3.6	2.0*
0	outriggers raised, on rail outriggers raised, on tyres 4 point outriggers down	10.0*	10.0*	6.5	7.4*	4.4	5.7*	2.9	4.2*	2.0*
-1.5	outriggers raised, on rail outriggers raised, on tyres 4 point outriggers down	6.8	11.2*	4.0	8.2*	2.6	6.0*	1.6	4.8*	1.3
-3.0	outriggers raised, on rail outriggers raised, on tyres 4 point outriggers down	9.1	11.2*	5.3	7.6	3.5	5.2	2.2	3.5	1.9
-4.5	outriggers raised, on rail outriggers raised, on tyres 4 point outriggers down	11.2*	11.2*	6.4	8.2*	4.4	6.0*	2.9	4.8*	2.1*

Height Can be slewed through 360° In longitudinal position of undercarriage Max. reach * Limited by hydr. capacity

The lift capacities are stated in metric tonnes (t) with PowerLift of 375 bar at the stick end without tools. This applies to a firm flat substrate with a closed steering axle. These capacities can be slewed through 360° over the undercarriage in the transverse position. Capacities in the longitudinal position of the undercarriage (+/- 15°) are specified over the steering axle with the stabilizers raised and over the rigid axle with the stabilizers down. The values apply when the adjusting cylinder is in the optimal position. Indicated loads based on the ISO 10567 standard and do not exceed 75% of tipping or 87% of hydraulic capacity, or are limited by the permissible load of the load lift hook.

In accordance with the harmonised European Standard EN 474-5, hydraulic excavators used for lifting operations must be equipped with pipe fracture safety valves, an overload warning device, a load lift hook and a lift capacity chart.

Please note that the stability will be reduced by approx. 20% in case of a 100 mm cant and 50% in case of a 200 mm cant.

Clamshell Grab

with Two-Piece Boom 5.10 m

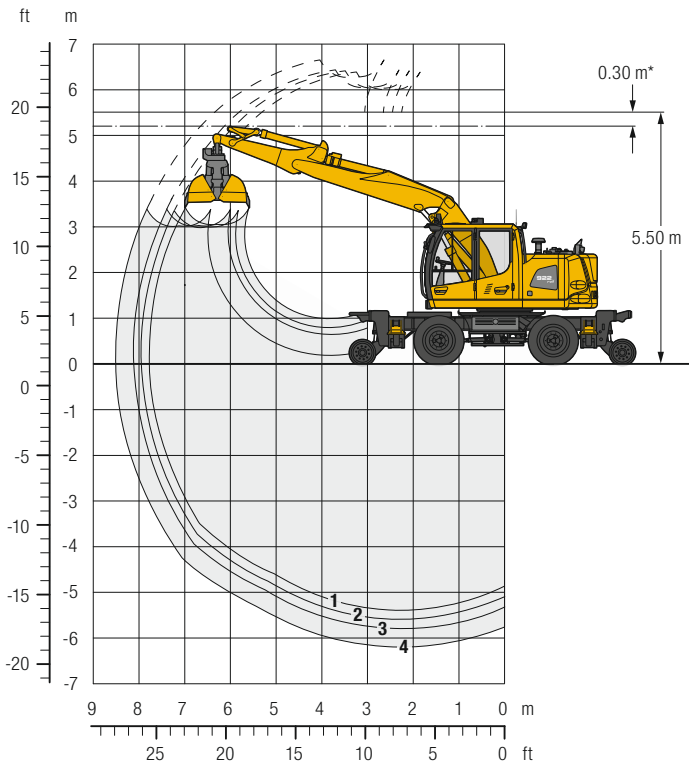

* Safety distance to overhead wires

Digging Envelope

		1	2	3	4
Stick length	m	1.85	2.05	2.25	2.65
Max. digging depth	m	5.40	5.60	5.80	6.20
Max. reach at ground level	m	7.75	7.95	8.10	8.50
Max. dumping height	m	6.00	6.05	6.05	6.30
Max. dumping height under overhead wires	m	3.05	3.00	3.00	3.00

Operating Weight

The operating weight includes the basic machine with 8 tyres plus intermediate rings, two-piece boom 5.10 m, stick 2.25 m and clamshell grab model GM 7C/0.35 m³.

Undercarriage versions	Weight (kg)
A 922 Rail Litronic Symetric Rail	20,400
A 922 Rail Litronic without outriggers	20,400
A 922 Rail Litronic with 4 point outriggers	22,100

Clamshell Grab Model GM 7C Machine stability per ISO 10567* (75% of tipping capacity)

Width of clamshells mm	Capacity m ³	Weight kg	without outriggers				4 pt. outriggers				Symetric Rail							
			on rail		on tyres		on rail		on tyres		on rail		on tyres					
			Stick length (m)	Stick length (m)	Stick length (m)	Stick length (m)	Stick length (m)	Stick length (m)	Stick length (m)	Stick length (m)	Stick length (m)	Stick length (m)	Stick length (m)	Stick length (m)				
300 ¹⁾	0.10	685	■	■	■	■	■	■	■	■	■	■	■	■	■	■	■	■
500 ²⁾	0.19	780	■	■	■	■	■	■	■	■	■	■	■	■	■	■	■	■
600 ²⁾	0.25	830	■	■	■	■	■	■	■	■	■	■	■	■	■	■	■	■
700 ²⁾	0.30	865	■	■	■	■	■	■	■	■	■	■	■	■	■	■	■	■
800 ²⁾	0.30	890	■	■	■	■	■	■	■	■	■	■	■	■	■	■	■	■
1,000 ²⁾	0.38	965	■	■	■	■	■	■	■	■	■	■	■	■	■	■	■	■
600 ³⁾	0.35	905	■	■	■	■	■	■	■	■	■	■	■	■	■	■	■	■
800 ³⁾	0.48	985	■	■	■	△	■	■	■	■	■	■	■	■	■	■	■	△
1,000 ³⁾	0.70	1,115	-	-	-	-	■	■	■	△	△	-	-	-	■	■	■	△

* Indicated loads are based on ISO 10567 and do not exceed 75% of tipping or 87% of hydraulic capacity, max. stick length without quick coupler, lifted 360° on firm with blocked oscillating axle

¹⁾ Special RR shells

²⁾ Comb. shells

³⁾ Digging shells

Max. material weight ■ = ≤ 1.8 t/m³, ■ = ≤ 1.5 t/m³, △ = ≤ 1.2 t/m³, - = not authorised

Clamshell Grab Model GM 7C

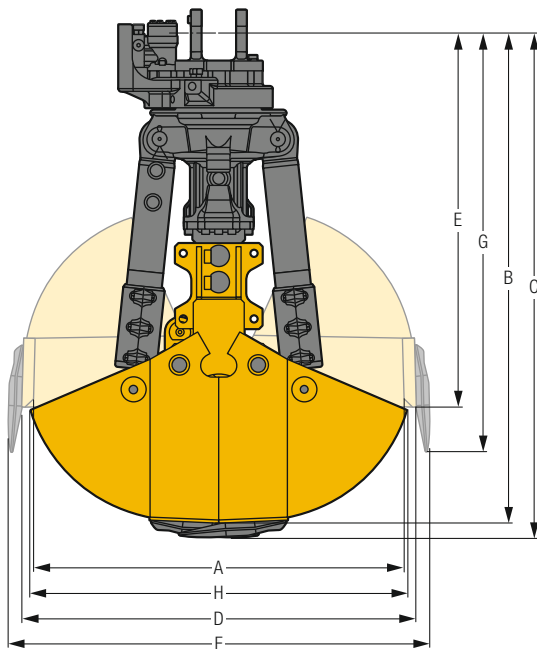

Scope of Delivery

	mm	Weight kg
Suspension		
suitable for quick change stick and standard pins		
Swing angle 45°	265	85
Swing angle 90°	370	90
for quick coupler SW33	645	165
Clamshell grab mechanism and clamshell carrier – upper part		
GM 7C		285
GM 7C-HD		310

Optional

	Weight kg
Ejectors (set of two)	
for special track clamshells and digging clamshells	
for clamshell width 300 mm	45
for clamshell width 600 mm	75
for clamshell width 800 mm	80

Dimensions / Weights

Capacity m ³	Shell width mm	Number of teeth Stück	Tine closed			Tine open			H Opening width mm	Weight without suspension kg	
			A Width mm	B Height mm	C Height with teeth mm	D Width mm	E Height mm	F Width with teeth mm			G Height with teeth mm
Track construction bucket (clamshell carrier splitted)											
0.10	300	3	1,143	1,492	1,534	1,200	1,139	1,284	1,275	1,128	595
Combination bucket (clamshell carrier splitted)											
0.19	500	5	1,189	1,542	1,585	1,298	1,140	1,386	1,258	1,225	690
0.25	600	5	1,189	1,542	1,585	1,298	1,140	1,386	1,258	1,225	740
0.30	700	7	1,189	1,542	1,585	1,298	1,140	1,386	1,258	1,225	775
0.30	800	7	1,189	1,542	1,585	1,298	1,140	1,386	1,258	1,225	800
0.38	1,000	9	1,189	1,542	1,585	1,298	1,140	1,386	1,258	1,225	875
Clamshell bucket (clamshell carrier splitted)											
0.35	600	5	1,439	1,677	1,723	1,568	1,140	1,657	1,262	1,495	815
0.48	800	7	1,439	1,677	1,723	1,568	1,140	1,657	1,262	1,495	895
0.70	1,000	7	1,439	1,677	1,723	1,568	1,140	1,657	1,262	1,495	1,025

Technical Data

Lift capacity max.	Grab open/close		Grab turning		Torque 1 motor 200 cm ³ 1.38 kNm
	Pressure max.	Flow max.	Pressure max.	Flow max.	
10 t	36 MPa	200 l/min.	15 MPa	30 l/min.	

Dimensions for Transport Choice of Bogie Systems

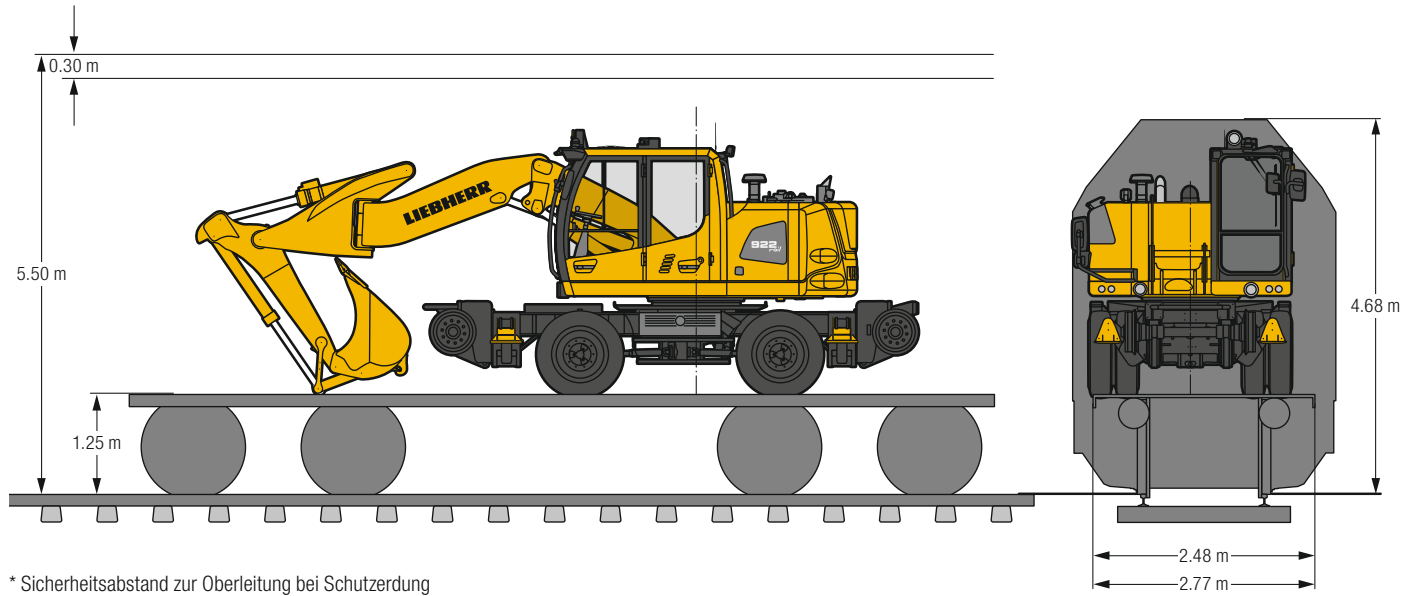

* Sicherheitsabstand zur Oberleitung bei Schutzerdung

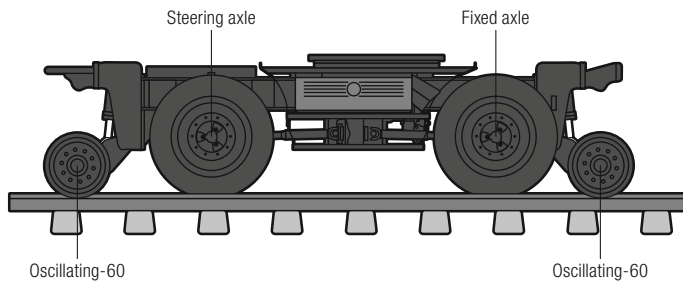

Variant A

steering axle end oscillating-60
rigid axle end oscillating-60

Area of application
for rail track unevenness

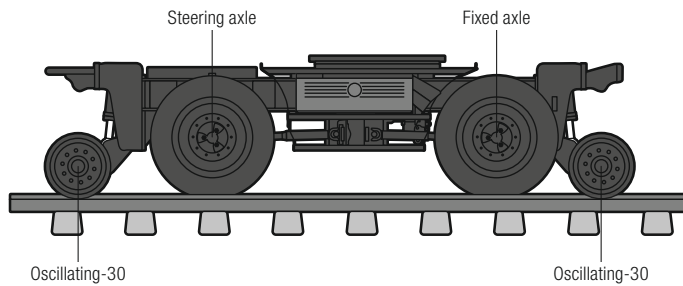

Variant B

steering axle end oscillating-30
rigid axle end oscillating-30

Area of application
for heavy loads / 4 point outriggers

Working Tools

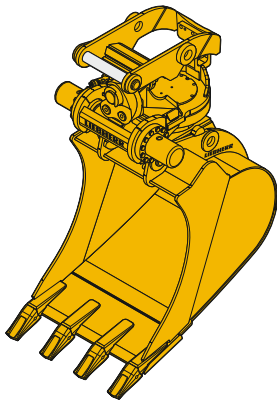

Tilt Rotator

Technical data

Slewing angle of 2 x 50°
360° rotation
Quick change stick/SW33/SW48/LIKUFIX

Description

The tilt rotator with its 360° rotatability, its patented tilt mechanism and a tilting angle of up to 50° offers a maximum of flexibility, specifically for channel digging. Its robust design makes it suitable for heavy operations.

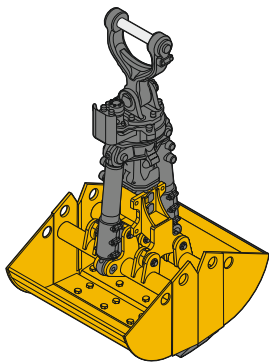

Clamshell Grab

Technical data

Width of clamshells 300 – 1,000 mm
Capacity 0.10 – 0.48 m³
Opening length 1,200 – 1,580 mm
Quick change stick/SW33/SW48/LIKUFIX

Description

It's possible to individually fit special track shells or grab shells with only one clam mechanism. The grab shells and teeth are standardly in HD-version, moreover the reinforced cutting sheets ensure a high stability.

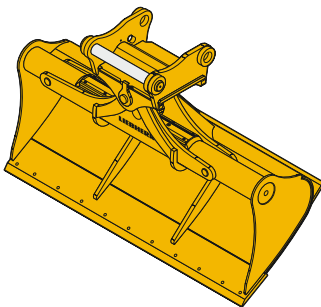

Ditch Cleaning Bucket

Technical data

Cutting width 1,600 and 2,000 mm
Capacity (SAE) 0.70 – 1.00 m³
Slewing angle of 2 x 50°
Quick change stick/SW33/SW48/LIKUFIX

Description

With the ditch cleaning bucket Liebherr offers a specific tool for railroader applications. The cutting edge persists parallelly to the rotation axis, so that it's also possible to drive around obstacles without any difficulty. This working tool makes racking, arranging and profiling an easy task. The cylinders are inside and therefore optimally protected.

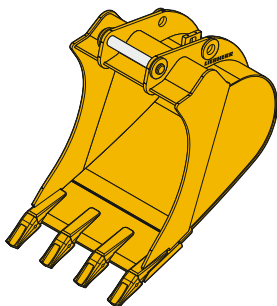

Backhoe Bucket

Technical data

Cutting width 550 – 1,250 mm
Capacity 0.28 – 0.55 m³
Quick change stick/SW33/SW48/LIKUFIX

Description

Liebherr offers a suitable backhoe bucket for nearly every application. A broad program in approved Liebherr quality and the appropriate quick hitch adapters provide a maximum of productivity.

Working Tools

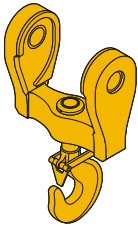

Load Lift Hook

Technical data

Lifting capacity up to 8 t
Mechanical 360° rotating
High-strength special type
Quick change stick/SW33/SW48/LIKUFIX

Description

Due to its low operating weight the Liebherr load hook allows the lifting of heavy loads. With this 360° rotatable tool it's possible to exactly deposit loads.

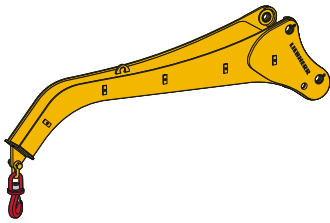

Load-Lifting Stick

Technical data

Length 2,500 mm
Integrated load hook 2.5 t
Quick change stick/SW33/SW48/LIKUFIX

Description

With the load-lifting stick an outreach of up to 10.0 m can be achieved. The load-lifting stick enables to work on the side rail track and to lift of long loads without any difficulty.

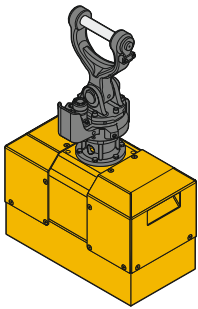

Hydro Magnet

Technical data

Hydro magnet II 5 kW
Lifting capacity up to 5 t
Swing drive 330°
Quick change stick/SW33/SW48/LIKUFIX

Description

The hydro magnet is particularly suitable for picking up small iron parts for applications in the area of rebuilding and deconstruction.

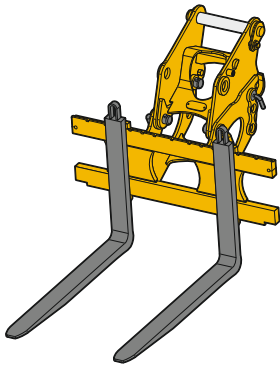

Pallet Fork

Technical data

Max. width pallet fork 1,245 mm
Pallet forks length 1,200 mm
Lifting capacity up to 2,5 t (ISO 2328)
Quick change stick/SW33/SW48/LIKUFIX

Description

Particularly well suited for transportation of pallets and pallet cages. Fast and secure setting of desired deployment height and width.

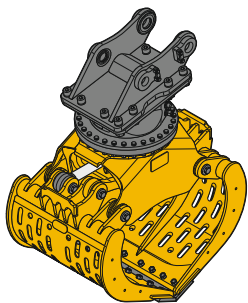

Sorting Grab

Technical data

Width of clamshells 800 – 1,400 mm
Capacity 0.40 – 1.10 m³
Opening length 1,200 – 1,970 mm
Quick change stick/SW33/SW48/LIKUFIX

Description

Sensitive working on sorting activities. Different tine shapes for individual applications available. High closing force combined with lightweight construction.

Equipment

Undercarriage

Dual-circuit braking system with rail wheel brake, hydraulically	•
4 point outriggers, outriggers rear and front	+
Support frame, lockable (front and rear)	+
Add-on-axle	+
Bumper (front and rear)	+
Trailer couplings	•
Lighting system white / red incl. power socket*	+
Earthing cable with ball-headed pin	✘
Travel speed levels (four)	•
Fire extinguisher 6 kg	✘
Grab suspension bracket	+
Drag shoe, 2 pieces	•
Coupling bar	✘
Line protection for rail guide cylinders	+
Parking brake, maintenance-free	•
Outrigger with individual control	+
Tyre inflation hose with pressure gauge at wagon braking system	+
Tyres, variants	+
Pipe fracture safety valves stabilizer cylinders	•
Rail undercarriage convertible (position and pressure control)	+
Rail guide axles, oscillating 30 on the steering axle side, 30 at the rear	•
Rail guide axles, oscillating 60 on the steering axle side, 60 at the rear	+
Rail sweeper, swivelling	+
Narrow excavator axles with wheel head width of 2,100 mm	+
Rail guide narrow gauge 1,000 mm	+
Protection for oscillating axle cylinders	+
Proportional servo-steering with emergency function	•
Special gauges	+
Speeder	+
Power socket 24 V / 10 A (front / rear)	+
Lashing eyelets for transport	•
Wagon braking system (hydraulic, 2 circuits)	+
Wagon braking system (pneumatic, 1 circuit)	•
Wagon braking system (pneumatic, 2 circuits)	+
Tool equipment, extended	+
Tool box left – lockable	•
Tool box right – lockable	•
Two-speed power shift transmission	•

Uppercarriage

Uppercarriage rear light, 2 pieces, halogen	+
Uppercarriage rear light, 2 pieces, LED	+
Uppercarriage right side light, 1 piece, LED	+
Refuelling system with filling pump	+
External starting aid	+
Handrails, non slip surfaces	•
Main battery switch for electrical system	•
Engine hood with gas spring	•
Uppercarriage doors, lockable	•
Signal light D.B., halogen	✘
Signal light D.B., LED	+
Special counterweight	+

Hydraulic System

Shut-off valve between hydraulic tank and pump(s)	•
Pressure test fittings	•
Accumulator for controlled lowering of the attachment with the engine shut down	•
Electronic pump regulation	•
High pressure circuit, continuous operation	•
Hydraulic oil filter with integrated microfilter	•
Liebherr hydraulic oil from –20 °C to +40 °C	•
Liebherr hydraulic oil, biologically degradable	+
Liebherr hydraulic oil, specially for warm or cold regions	+
Bypass filter	+
Emergency actuation, electric	✘
Priority circuit LSC for attachments	•
Electric switchover clamshell operation and tipping cylinder	•
Switchover high pressure circuit 1 and tipping cylinder	+
Switchover high pressure circuit 1 and two-piece boom	+
Preparation Liebherr hydro-magnet	+

Diesel Engine

Fuel anti-theft device	+
Sensor controlled engine idling	•
Liebherr particle filter	+
Air pre-filter with dust discharge	+
Pre-installation particle filter with sound attenuation module	•
Preheating hydraulic oil	+
Preheating fuel	+
Preheating coolant	+
Preheating engine oil	+

Work Space Limitation

Electronic lift limitation	✘
Load torque limitation (RCI/RCL)	✘
Swivel limitation	✘
Overload warning device*	+
Virtual wall	+

Equipment



Operator's Cab

Storage compartment	•
Cab lights rear, halogen	•
Cab lights rear, 2 pieces, LED	+
Cab lights front, halogen (under rain cover)	•
Cab lights front, 2 pieces, LED (under rain cover)	+
Left arm console, folding	•
Exterior mirror, electrical adjustable, with heating	+
Control elements for signal-horn and emergency brake at co-driver's seat	•
Mechanical hour meters, readable from outside the cab	•
Roof window made from impact-resistant laminated safety glass	•
Data logger	✘
Two seater cab	•
Circular bubble level	+
Pressure indication of rail axles on the display	•
Driver identification code	+
Driver profile, personalised	•
Operator's seat Standard	•
Operator's seat Comfort	+
Operator's seat Premium	+
Driving alarm (acoustic signal is emitted during travel, can be switched ON/OFF)	+
Fire extinguisher 2 kg	+
Windscreen retractable (including upper part)	•
Intermittent windscreen wiper with wiper washer	•
Footrest	+
Speed indication on the rail-display	•
Cruise control	•
Rubber floor mat, removable	•
Dome light	•
Licence plate holder with light	+
Coat hook	•
Automatic air conditioning	•
Fuel consumption indicator	•
Electric cooler	+
Steering wheel lock	•
Steering column adjustable	•
LiDAT Plus (extended Liebherr data transfer system)**	•
Emergency exit rear window	•
Positioning swing brake	•
Proportional control	•
Radio Comfort, control via display with handsfree set	+
Preparation for radio installation	•
Rain cover over front window opening	•
ROPS cab	•
Back-up alarm (acoustic signal is emitted traveling backward, can not be switched off)	+
Warning beacon on cab	+
Windshield wiper with interval switching and washer, roof window	•
Windshield wiper with interval switching and washer, rear window	•
Driver door with sliding window	•
Slipcover for operator seat	+
Right side window and windshield made from laminated safety glass	•
Safety components DB (safety flag, signal horn, warning triangle, warning light)	✘
Sun blind	•
Auxiliary heating, adjustable (week time switch)	+
Power socket 12 V	•
Electronic immobilizer	+
Cigarette lighter / power socket 24 V	•

• = Standard, + = Option, ✘ = Required for acceptance by the German RR (DB)

* = country-dependent, ** = optionally extendable after one year

Options and/or special attachments, supplied by vendors other than Liebherr, are only to be installed with the knowledge and approval of Liebherr in order to retain warranty.



Attachment

Alternative connection medium pressure circuit on right side of stick	+
Boom lights, 2 pieces, halogen	•
Boom lights, 2 pieces, LED	+
Stick lights, 2 pieces, halogen	+
Stick lights, 2 pieces, LED	+
High pressure circuit 1 incl. unpressurised return line and Tool Control	•
High pressure circuit 2 incl. lines	•
Hydraulic lines for grab operation	•
Free rotating load lift hook	+
Load holding valve bucket cylinder	+
Load lug on boom	+
Load lug on stick	+
Leak oil line, additional for working tools	•
Liebherr ditch cleaning bucket	+
Liebherr quick coupler, hydraulic or mechanical	+
Liebherr tilt bucket	+
Liebherr tilt rotator	+
Liebherr sorting grab	+
Liebherr backhoe bucket	+
Liebherr tooth system	+
Liebherr clamshell grab	+
Stick prepared for quick coupler stick	•
Medium pressure circuit incl. lines	•
Pipe fracture safety valves hoist cylinders	•
Pipe fracture safety valve stick cylinder	•
Hose quick coupling at grab lines	•
Quick coupling system LIKUFIX	+
Special buckets and other attachments	+
Power socket on stick, 24 V / 15 A, 20 A switchable	+
Tool Control, 10 tool adjustments selectable over the display	•
Tool Management, automatic tool recognition (in combination with LIKUFIX 48)	+
Latching for connecting link in grab operation	+
Two-piece boom	•
Offset two-piece boom	+
Cylinders with end damping	•



Complete Machine

Lubrication	
Lubrication undercarriage, manually – decentralised (grease points)	•
Lubrication undercarriage steering axle, manually – centralised (one grease point)	+
Central lubrication system for uppercarriage and attachment, automatically (without quick coupler and connecting link)	•
Central lubrication system, extension for quick coupler	+
Central lubrication system, extension for connecting link	+
Special coating	
DB-coating	✘
Special coating undercarriage, uppercarriage, equipment (without DB-permission)	+
Monitoring	
Rear view monitoring with camera	•
Side view monitoring with camera	•

Liebherr-Hydraulikbagger GmbH

Liebherrstraße 12, D-88457 Kirchdorf/Iller

☎ +49 7354 80-0, Fax +49 7354 80-72 94

www.liebherr.com, E-Mail: info.lhb@liebherr.com

www.facebook.com/LiebherrConstruction